

Irrigation Catalog

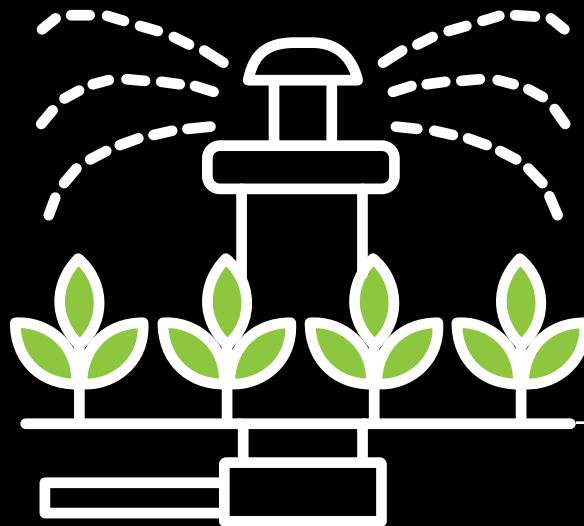

AGRICULTURE





Irrigation

INDEX

CERTIFICATION.....	4
SOLENOID VALVES.....	7
SOLENOID MANIFOLDS.....	29
ISOLATED / FERTILIZER.....	33
SOLENOIDS.....	33
ELECTRIC & HYDRAULIC VALVES.....	41
ELECTRIC & HYDRAULIC VALVES G500.....	67
CONTROLLERS & SPECIAL VALVES.....	83
OPERATORS & COILS.....	103
TECHNICAL INFORMATION.....	115



CERTIFICATION



ISO 9001:2015

Quality Management System: Design, production, testing and marketing of solenoid valves and automation control equipment



ISO 14001:2015

Environmental Management System: Design, production, testing and marketing of solenoid valves and automation control equipment



OHSAS 18001:2007

Occupational Health & Safety Management System: Design, production, testing and marketing of solenoid valves and automation control equipment



EN55011 Group1 - Class A / EN61000-6-1 / CFR 47 FCC Class A
EMC - SII Certificate of Conformity



UL 429

Standard for electrically operated valves
Available on selected models only



CE

EC Declaration of Conformity
Complies with the requirements and provisions of the Council Directive 2014/35/EU
Available on selected models only



FCC

Product certification from The Federal Communications Commission
Available on selected models only



NSF/ANSI 61 & 372 *

NSF/ANSI 61 & 372 and all applicable requirements
Drinking Water System Components:
Lead Content | Health Effects
Available on selected models only

For details of all NSF certified Baccara products, please take the following steps:

- Visit **NSF Public Health & Safety Organization: www.nsf.org**
- Click on **[SEARCH CERTIFIED PRODUCTS & SYSTEMS >>](#)**
- Type "**Baccara**" in the "**search company**" field > **Enter**



AS/NZS 4020:2005 *

Certificate of Conformity: Testing of products for use in contact with drinking water
Available on selected models only

* For enquiries regarding this certification, please contact BACCARA sales engineers at water@baccara-geva.com

b **BACCARA**[®]
AUTOMATION & CONTROL



SOLENOID VALVES

Contents

GEM-FLOW G75-A3P	1/8" Latch 2 Way, 3 Way NC, NO	8
GEM-FLOW G75-VSA	Stand-alone Solenoid 3 Way NC, NO	10
GEM-FLOW G75-P	3 Way Pilot Operated NC, NO	12
GEM-FLOW G75-A	1/8", 1/4" 2 Way, 3 Way NC, NO	14
GEM-FLOW GALIT	3 Way Pilot Operated NC, NO	16
GEM-SOL GEM-A	1/8", 1/4" 2 Way NC, NO	18
GEM-SOL GEM-A	1/8", 1/4" 2 Way NC, NO	20
GEM-SOL GEM-A	1/8", 1/4" 3 Way NC, NO	22
GEM-SOL GEM-A	1/8", 1/4" 3 Way NC, NO	24
GEM-SOL GEM-A3P	Latch 3 Positioning Manual Override, 2 Way, 3 Way NC, NO	26



SOLENOID VALVES

GEM-FLOW | G75-A3P

1/8" Latch 2 Way, 3 Way NC, NO

Technical Data

Function	2 Way NC, 3 Way NC, NO
Ports size	1/8" BSP & NPT
Orifice size	2.6 mm
Pressure range	NC 2 Way: 10 bar NC 3 Way: 8 bar NO 3 Way: 10 bar
Temperature range	Fluid: 5°C to 50°C (no freezing) Ambient: -10°C to 50°C
Materials in contact with media	Manual override: Plastic (Reinforced Nylon) NO: Red NC: Green Main Valve: UV Stabilized - Reinforced Nylon 6 30% GF Solenoid Operator: Stainless Steel AISI 300 & 400 series Seals: NBR
Mounting	2 x Ø6 mm holes
Manual override	3 positions (Open/Auto/Close)
Media	Air, water
Coil voltage	Latch
Switching time	40-60 msec
Electric connection	22AWG cable
Standard protection class	IP66

- * Can only be operated with supplied coil
- * Available with a manifold bracket upon request.
Please contact our technical sales department



Latch Coil Resistance vs Input Voltage

Recommendations chart

Resistance [Ω]	Input voltage range [V]
1	8 - 12
4	12 - 18
9	18 - 24

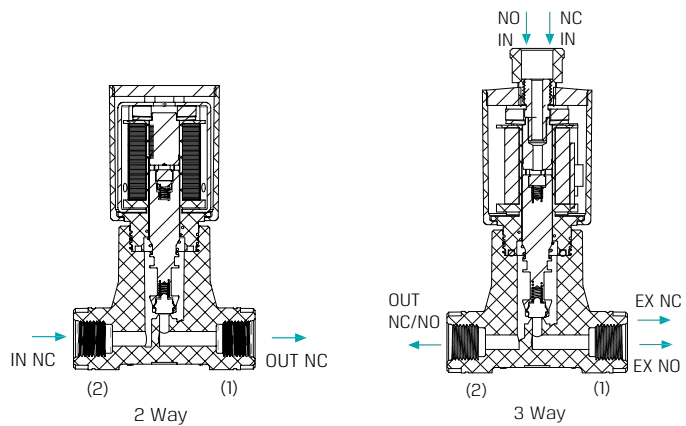

Dimensions

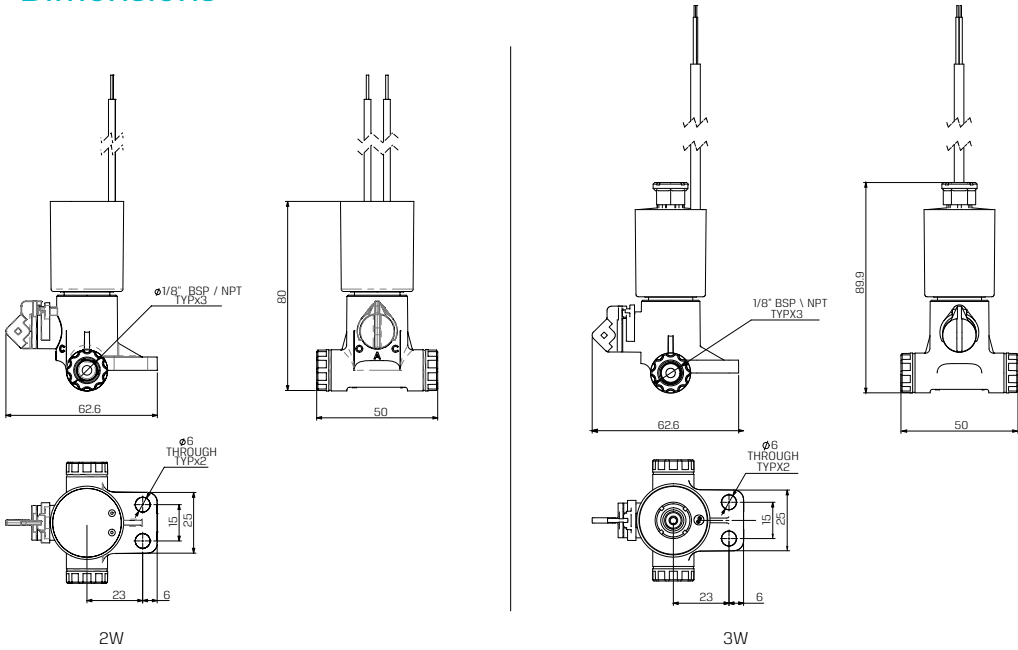

Manual Override Operation

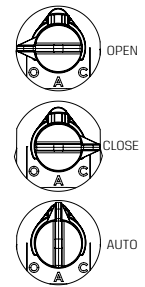

To manually open the valve:
turn selector switch to OPEN

NO: To change from OPEN to AUTO:
turn the selector switch to AUTO

NC: To change from OPEN to AUTO:
turn the selector switch to CLOSE,
and then to AUTO

How to Order

G75-A3P -	TYPE	PORT	FUNCTION ⁽¹⁾	ORIFICE	LATCH TYPE ⁽²⁾	WIRES
with flange	1	1/8" BSP	10	2W NC 1	2.6 5a	1Ω PA two Null
		1/8" NPT	11	3W NC 3		4Ω PB three a
				3W NO 4		9Ω PC

Example: G75-A3P-11015a-PA

G75-A3P, with flange, 1/8"BSP, 2W NC, 2.6 orifice, 1 latch with two wires

G75-A3P - 1 10 1 5a - PA

(1) To order NC configuration, please consult with our technical sales department

(2) Refer to Latch Coil Resistance vs Input Voltage Recommendations chart

* To order valves manufactured according to your specific requirements, please contact our technical sales department

SOLENOID VALVES

GEM-FLOW | G75-VSA

Stand-alone Solenoid 3 Way NC, NO

Technical Data

Function	3 Way NC, NO
Ports size	1/8" BSPT & NPT
Orifice size	1.8 mm
Pressure range	0 to 8 bar
Switching time	30-50 ms
Temperature range	Fluid: 0°C to 50°C (no freezing) Ambient: -10°C to 50°C
Materials in contact with media	Manual override: Plastic (Reinforced Nylon) Main Valve: Plastic (Reinforced Nylon & POM) Solenoid Operator: Stainless Steel AISI 300 & 400 series Seals: EPDM
Mounting	Lock nut on the bottom COM port
Manual override	Latch: 3 position latch: Auto, Close, Open AC: 2 position: Auto, Open
Media	Air, water
Coil voltage	Latch, AC (according to table)
Standard protection class	IP66

* Can **only** be operated with supplied coil



PORT	NO	NC
1	Exhaust	Pressure
3	Pressure	Exhaust
COM	Out	Out

Voltage & Current

AC & DC

Solenoid	Inrush [A]	Holding [A]
24VAC-50 Hz	0.33	0.21

Latch Coil Resistance vs Input Voltage

Recommendations chart

Resistance [Ω]	Input voltage range [V]
4	6 - 9
9	12 - 14
12	14 - 16
23	18 - 21

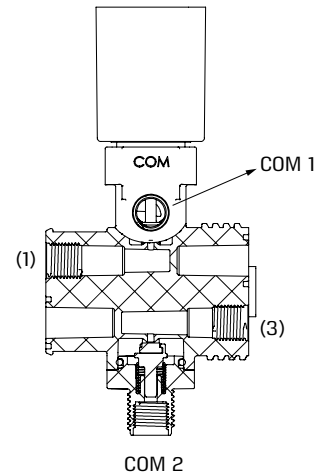

Dimensions

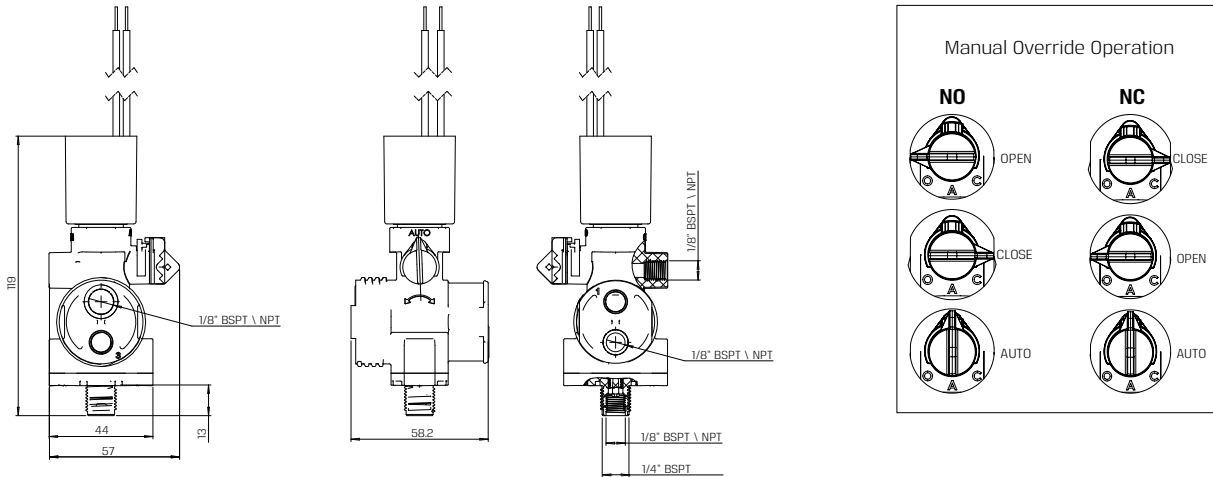

How to Order

G75-VSA	BODY	PORT	FUNCTION	MANUAL OVERRIDE	ORIFICE	SEALS	TYPE	OUTLET ⁽³⁾	WIRES
Plastic	4	1/8" BSPT 10	3W NC 3	Plastic 1	1.8 3a	EPDM E	24VAC-50Hz ⁽¹⁾ S1	COM 1 1	two Null
		1/8" NPT 11	3W NO 4				4Ω ⁽²⁾ SB	COM 2 2	three ⁽⁴⁾ a
							9Ω ⁽²⁾ SC		
							12Ω ⁽²⁾ SD		
							23Ω ⁽²⁾ S6		

Example: G75-VSA-410313aE-SB1

G75-A stand-alone solenoid, plastic, 1/8" BSPT, 3W NC, plastic manual override, 1.8 orifice, EPDM seals, 4 latch, COM 1 outlet, two wires

G75-VSA - 4 10 3 1 3a E - SB 1

(1) Refer to Voltage & Current AC & DC

(2) Refer to Latch Coil Resistance vs Input Voltage | Recommendations chart

(3) A plug will be fitted on the other outlet port

(4) Latch only

* To order valves manufactured according to your specific requirements, please contact our technical sales department

SOLENOID VALVES

GEM-FLOW | G75-P

3 Way Pilot Operated NC, NO

Technical Data

Function	3 Way NC, NO
Ports size	1/4" BSP & NPT
Orifice size	6.5mm
Pressure range	0.5 to 10 bar
Temperature range	Fluid: 5°C to 50°C (no freezing) Ambient: -10°C to 50°C
Materials in contact with media	Main Valve: Plastic (Reinforced Nylon) Solenoid Operator: Stainless Steel 300 & 400 series Seals: NBR Spring: Stainless Steel AISI 300 series
Manual override	Manual override with 2 positions: • AUTO - for automatic operation • MANUAL - for manual operation NO: Red NC: Green
Solenoid	Assembled with 3 Way NO 1.2mm G75 operator
Coil voltage	• Voltage and power consumption - see table
Standard protection class	IP66

* Available with a manifold bracket upon request.
Please contact our technical sales department



Voltage & Current

AC & DC

Solenoid	Voltage	Inrush [A]	Holding [A]
3 Way 24VAC 50/60 Hz *	V +10% n-20%	0.125	0.125
DC		4.5W	

* Except 24V AC without Diode

Voltage & Power Consumption

V	AC (W)	DC (W)
	50 Hz	
12	•	•
24	•	•

* Available options

Latch Coil Resistance vs Input Voltage

Recommendations chart

Resistance [Ω]	Input voltage range [V]
4	6 - 9
9	12 - 14
12	14 - 16
23	18 - 21

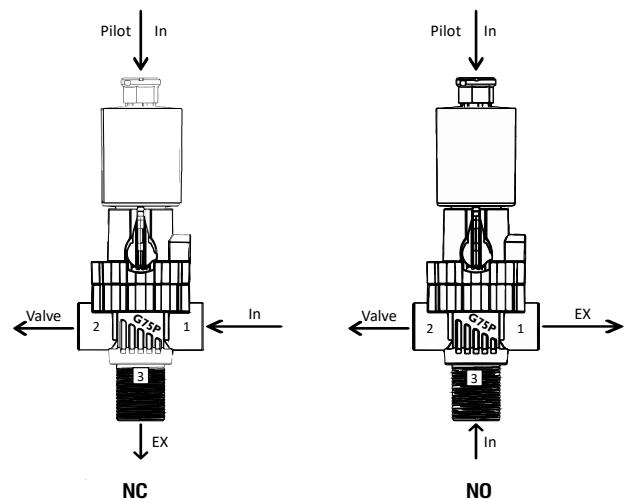

Hydraulic Connections

Dimensions

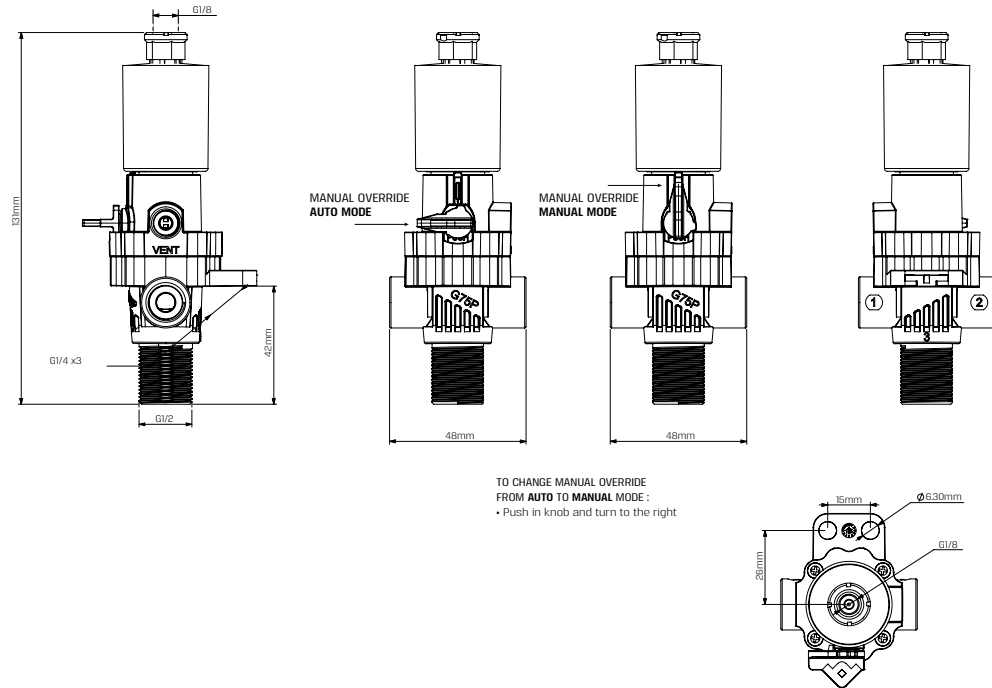

How to Order

G75-P	PORT	VOLTAGE ⁽¹⁾	MOUNTING BRACKET	WIRES
1/4" BSP	20	24V AC	1	without 0 two null
1/4" NPT	21	24V AC w/out Diode	1R	with 1 three ⁽²⁾ a
		12V AC	3	
		12V DC	4	
		24V DC	5	
		23 Ω	6	
		4 Ω	B	
		9 Ω	C	
		12 Ω	D	

Example: G75-P-2011

G75-P pilot operated, 1/4" BSP, 24V AC with mounting bracket, two wires

G75-P - 20 1 1

(1) For Latch: Refer to Latch Coil Resistance vs Input Voltage | Recommendations chart

(2) For Latch only

* To order valves manufactured according to your specific requirements, please contact our technical sales department

SOLENOID VALVES

GEM-FLOW | G75-A

1/8", 1/4" 2 Way, 3 Way NC, NO

Technical Data

Function	2 Way, 3 Way NC, NO
Ports size	1/8" and 1/4" BSP & NPT
Orifice size	See table
Pressure range	See table
Temperature range	Fluid: 5°C to 50°C (no freezing) Ambient: -10°C to 50°C
Materials in contact with media	Manual override: Plastic (Reinforced Nylon) Main Valve: Brass or Plastic (Reinforced Nylon) Solenoid Operator: Stainless Steel AISI 300 & 400 series Seals: EPDM
Coil voltage	• Voltage and power consumption - see table
Standard protection class	IP66

* Available with a manifold bracket upon request.
Please contact our technical sales department



G75-A
Brass

G75-A | 2 Way
Plastic

G75-A | 3 Way
Plastic

Latch Coil Resistance vs Input Voltage

Recommendations chart

Resistance [Ω]	Input voltage range [V]
4	6 - 9
9	12 - 14
12	14 - 16
23	18 - 21

Max. Pressure (bar)

Function	Orifice (mm)	AC	DC	DC Latch
2 Way NC	up to 2.0	12	12	12
3 Way NC	1	16	12	16
	1.2	11	9	11
	1.6	6	5	6
3 Way NO	1.0	16	16	16
	1.2	12	12	12
	1.6	10	10	10

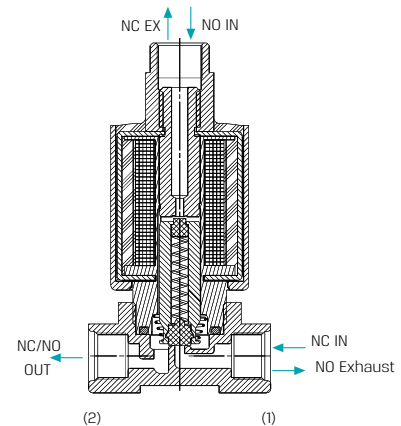

Voltage & Current

AC & DC

Solenoid	Voltage	Inrush [A]	Holding [A]
2 Way 50 Hz	+10%	0.3	0.19
2 Way 60 Hz		0.2	0.14
3 Way 50/60 Hz *		0.125	0.125
DC	n-20%	4.5W	

* Except 24V AC without Diode

Voltage & Power Consumption

V	AC (W)	DC (W)
	50 Hz	
2	2	4.5
12	•	•
24	•	•
110	• 2 Way only	

* Available options

Dimensions

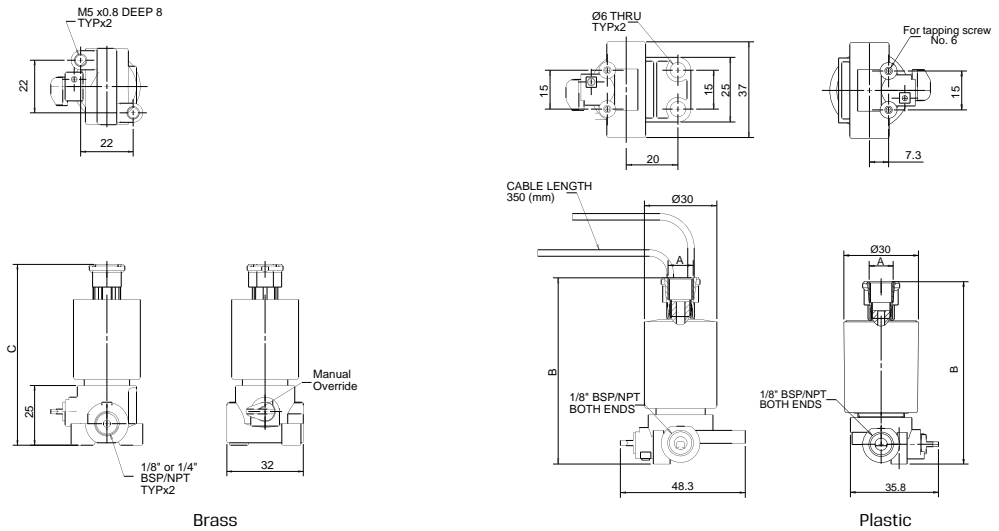

	A	B	C
2 Way NC	-	59	65
3Way	1/8	70	77

How to Order

G75-A	-	TYPE	PORT	FUNCTION	MANUAL OVERRIDE	ORIFICE	-	VOLTAGE ⁽³⁾	WIRES						
		with flange	1	1/8" BSP	10	2W NC	1	None	0	1.0 ⁽¹⁾	1	24V AC	1	two	null
		Brass	3	1/8" NPT	11	3W NC	3	Plastic ⁽²⁾	1	1.2	2	24V AC w/out Diode ⁽⁴⁾	1R	three ⁽⁵⁾	a
				1/4" BSP ⁽¹⁾	20	3W NO	4			1.6	3	12V AC	3		
				1/4" NPT ⁽¹⁾	21					2.0 ⁽¹⁾	4	12V DC	4		
												24V DC	5		
												23Ω	6		
												110V AC	7		
												4Ω	B		
												9Ω	C		
												12Ω	D		

Example: G75-A-110302-1

G75 with flange, 1/8" BSP, 3W NC, no manual override, 1.2 orifice, 24V AC coil, two wires

G75-A - 1 - 10 - 3 - 0 - 2 - 1

- (1) Brass only
- (2) Recommended for AC and continuous DC only
- (3) For Latch: Refer to Latch Coil Resistance vs Input Voltage | Recommendations chart
- (4) 3W NO 1.6 mm: Max pressure is 8 bars
- (5) For Latch only

* To order valves manufactured according to your specific requirements, please contact our technical sales department

SOLENOID VALVES

GEM-FLOW | GALIT

3 Way Pilot Operated NC, NO

Technical Data

Function	3 Way NC, NO
Ports size	1/8" BSP & NPT
Orifice size	5mm
Pressure range	1 to 10 bar
Temperature range	Fluid: 5°C to 50°C (no freezing) Ambient: -10°C to 50°C
Materials in contact with media	Main Valve: Plastic (Reinforced Nylon) Solenoid Operator: Stainless Steel 300 & 400 series Seals: NBR Spring: Stainless Steel AISI 300 series
Manual override	Manual override with 3 positions: • AUTO - for automatic operation (valve is open when solenoid is energized) • MANUAL - valve is kept open • CLOSE - valve is kept closed
Solenoid	Assembled with 3W NO 1.2mm G75 operator
Coil voltage	• Voltage and power consumption - see table
Standard protection class	IP66

* Available with a manifold bracket upon request.
Please contact our technical sales department



Voltage & Current

AC & DC

Solenoid	Voltage	Inrush [A]	Holding [A]
2 Way 50 Hz	V +10% -20%	0.3	0.19
2 Way 60 Hz		0.2	0.14
3 Way 50/60 Hz *		0.125	0.125
DC		4.5W	

* Except 24V AC without Diode

Voltage & Power Consumption

	AC (W) 50 Hz	DC (W)
V	2	4.5
12	•	•
24	•	•

* • Available options

Latch Coil Resistance vs Input Voltage

Recommendations chart

Resistance [Ω]	Input voltage range [V]
4	6 - 9
9	12 - 14
12	14 - 16
23	18 - 21

Dimensions

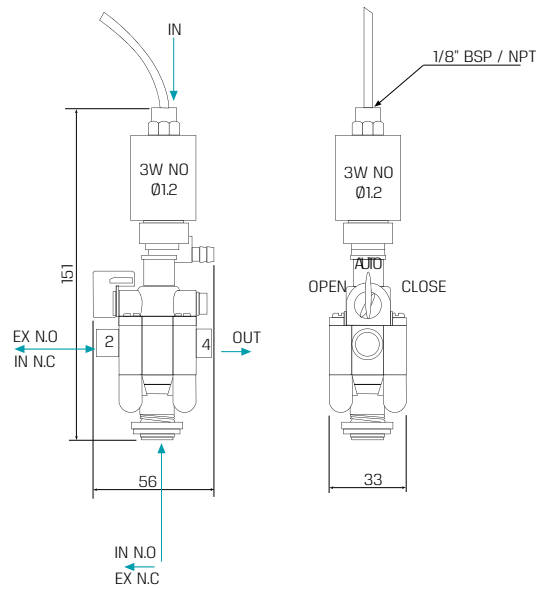

How to Order

GALIT	-	PORT	VOLTAGE ⁽¹⁾		MOUNTING BRACKET		WIRES		
		1/8" BSP	10	24V AC	1	without	0	two	null
		1/8" NPT	11	24V AC w/out Diode	1R	with	1	three ⁽²⁾	a
				12V AC	3				
				12V DC	4				
				24V DC	5				
				23Ω	6				
				4Ω	B				
				9Ω	C				
				12Ω	D				

Example: GALIT-1011

GALIT pilot operated, 1/8" BSP, 24V AC with mounting bracket, two wires

GALIT - 10 1 1

(1) For Latch: Refer to Latch Coil Resistance vs Input Voltage | Recommendations chart

(2) For Latch only

* To order valves manufactured according to your specific requirements, please contact our technical sales department

SOLENOID VALVES

GEM-SOL | GEM-A

1/8", 1/4" 2 Way NC, NO

Technical Data

Function	2 Way NC, NO
Ports size	1/8" and 1/4" BSP & NPT
Orifice size	See table
Pressure range	<ul style="list-style-type: none"> • See table • Valves for pressure higher than 25 bar cannot be supplied with manual override
Kv (l/min)	See table
Temperature range	Fluid: -10°C to 80°C (no freezing) Ambient: -10°C to 50°C
Materials in contact with media	Manual override: Plastic (Reinforced Nylon), Brass screw or Brass finger knob, Stainless Steel for Stainless Steel valves (1) Plastic manual override: Maximum pressure: 16 bar (2) Manual override is unavailable in 2 Way NO through base applications Main Valve: Brass or Stainless Steel AISI 316 Solenoid Operator: Stainless Steel AISI 300 & 400 series Seals: NBR, FKM, EPDM, FFKM, PTFE
Media	Air, water, oil
Coil voltage	<ul style="list-style-type: none"> • Voltage and power consumption - see table • All Baccara coil voltages are ± 10% of nominal
Standard protection class	IP65 with connector * Option: IP68 (please refer to GEM-BP Coil)

- Latch valves are available upon request
- * Available with a manifold bracket upon request. Please contact our technical sales department



GEM-A | 2 Way Stainless Steel



GEM-A | 2 Way Brass

Max. Pressure (bar) 2 Way NC

Coil Current/Power	Orifice (mm)						
	0.8	1.2	1.6	2.0	2.4	3.0	4.0
ADC *	60	50	35	20	15	10	5
AC8W, DC/10W	80	80	60	38	30	18	10
AC5.5W	80	60	40	28	20	15	6
AC2.5W	60	50	35	20	15	9	5
DC5.5W	60	30	18	12	9	6	3
DC3.5W	40	20	12	8	6	4	2
Flow factor Kv(l/min)	0.5	1.1	1.7	2.5	3.5	4.5	5

Max. Pressure (bar) 2 Way NO

Coil Current/Power	Orifice (mm)				
	0.8	1.2	1.6	2.0	3.0
ADC *	25	25	25	20	10
Flow factor Kv(l/min)	0.5	1.1	1.4	2.5	3.5

- * ADC valves are only suitable for use with AC8W or DC10W coils

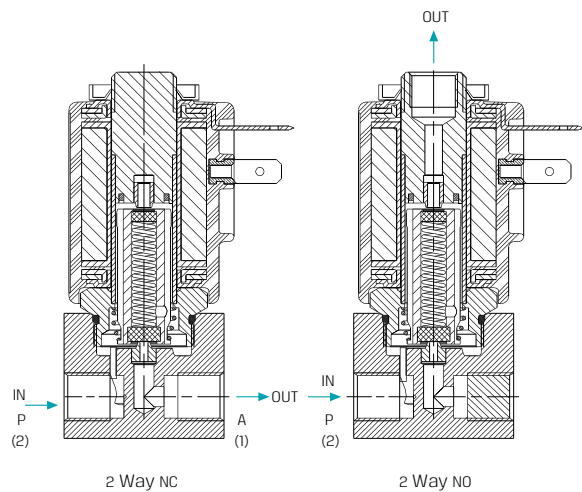

Dimensions

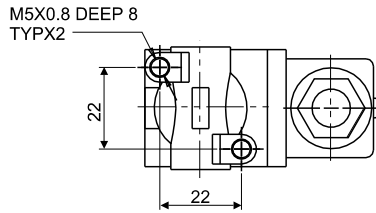

Optional Mounting Bracket

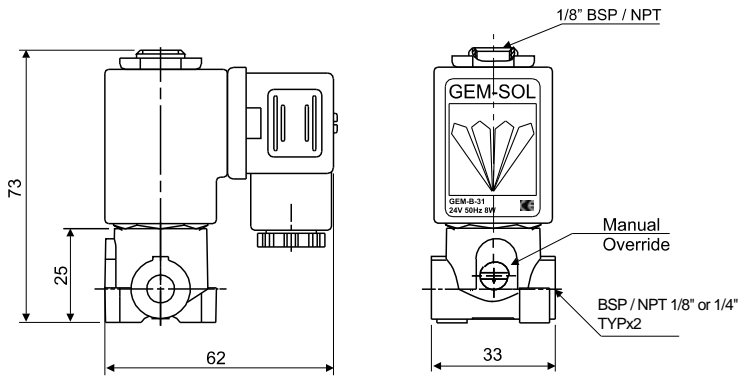
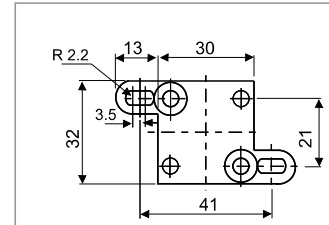

Brass / Stainless Steel

SOLENOID VALVES

GEM-SOL | GEM-A

1/8", 1/4" 2 Way NC, NO

Three Product Ordering Categories available

- STANDARD** | Reduced lead times, No MOQ
- SEMI-STANDARD** | Normal lead times, No MOQ
- SPECIAL** | Extended lead times, Non-stock items, MOQ may be applicable

Ordering Chart

Standard items | Reduced lead times, No MOQ
ADC operator only

MODEL	PORT	FUNCTION	ORIFICE (mm)	SEAL MATERIAL	MANUAL OVERRIDE	CONNECTOR	MOPD (bar)	PART NO. PER VOLTAGE & POWER			
								24VDC 10W	24VAC 8W 50Hz	110VAC 8W 60Hz	230VAC 8W 50Hz
GEM-A BRASS	1/8" BSP	2W NC	1.6	NBR	Slot	with	35	1253820062 GEM-A-21013N2-331 ADC	1253820063 GEM-A-21013N2-311 ADC	1253820064 GEM-A-21013N2-521 ADC	1253820065 GEM-A-21013N2-711 ADC
			20				1253820218 GEM-A-21014N2-331 ADC	1253820203 GEM-A-21014N2-311 ADC	1253820219 GEM-A-21014N2-521 ADC	1253820220 GEM-A-21014N2-711 ADC	
			15				1253830041 GEM-A-21015N2-331 ADC	1253830048 GEM-A-21015N2-311 ADC	1253830049 GEM-A-21015N2-521 ADC	1253830050 GEM-A-21015N2-711 ADC	
	35		1253820066 GEM-A-21113N2-331 ADC				1253820067 GEM-A-21113N2-311 ADC	1253820068 GEM-A-21113N2-521 ADC	1253820069 GEM-A-21113N2-711 ADC		
	20		1253820221 GEM-A-21114N2-331 ADC				1253820222 GEM-A-21114N2-311 ADC	1253820223 GEM-A-21114N2-521 ADC	1253820224 GEM-A-21114N2-711 ADC		
	15		1253830051 GEM-A-21115N2-331 ADC				1253830052 GEM-A-21115N2-311 ADC	1253830053 GEM-A-21115N2-521 ADC	1253830054 GEM-A-21115N2-711 ADC		
	1/8" NPT	2W NC	1.6	NBR	Slot	with	35	1255820108 GEM-A-22013N2-331 ADC	1255820031 GEM-A-22013N2-311 ADC	1255820109 GEM-A-22013N2-521 ADC	1255820110 GEM-A-22013N2-711 ADC
			20				1255820301 GEM-A-22014N2-331 ADC	1255820302 GEM-A-22014N2-311 ADC	1255820303 GEM-A-22014N2-521 ADC	1255820304 GEM-A-22014N2-711 ADC	
			15				1255830201 GEM-A-22015N2-331 ADC	1255830202 GEM-A-22015N2-311 ADC	1255830203 GEM-A-22015N2-521 ADC	1255830580 GEM-A-22015N2-711 ADC	
	35		1255820111 GEM-A-22113N2-331 ADC				1255820112 GEM-A-22113N2-311 ADC	1255820113 GEM-A-22113N2-521 ADC	1255820114 GEM-A-22113N2-711 ADC		
	20		1255820305 GEM-A-22114N2-331 ADC				1255820306 GEM-A-22114N2-311 ADC	1255820307 GEM-A-22114N2-521 ADC	1255820308 GEM-A-22114N2-711 ADC		
	15		1255830205 GEM-A-22115N2-331 ADC				1255830206 GEM-A-22115N2-311 ADC	1255830207 GEM-A-22115N2-521 ADC	1255830208 GEM-A-22115N2-711 ADC		

*Standard coils are not vacuum impregnated

GEM-A SST	1/4" BSP	2W NC	1.6	FKM	Slot	with	35	1255820311 GEM-A-32013V2-331 ADC	1255820312 GEM-A-32013V2-311 ADC	1255820313 GEM-A-32013V2-521 ADC	1255820314 GEM-A-32013V2-711 ADC
			20				1255820315 GEM-A-32014V2-331 ADC	1255820316 GEM-A-32014V2-311 ADC	1255820317 GEM-A-32014V2-521 ADC	1255820318 GEM-A-32014V2-711 ADC	
			15				1255830211 GEM-A-32015V2-331 ADC	1255830531 GEM-A-32015V2-311 ADC	1255830213 GEM-A-32015V2-521 ADC	1255830214 GEM-A-32015V2-711 ADC	
	1/4" NPT		35				1255820321 GEM-A-32113V2-331 ADC	1255820322 GEM-A-32113V2-311 ADC	1255820323 GEM-A-32113V2-521 ADC	1255820324 GEM-A-32113V2-711 ADC	
			20				1255820325 GEM-A-32114V2-331 ADC	1255820326 GEM-A-32114V2-311 ADC	1255820327 GEM-A-32114V2-521 ADC	1255820328 GEM-A-32114V2-711 ADC	
			15				1255830215 GEM-A-32115V2-331 ADC	1255830216 GEM-A-32115V2-311 ADC	1255830217 GEM-A-32115V2-521 ADC	1255830218 GEM-A-32115V2-711 ADC	

Model Selection

STANDARD | Reduced lead times, No MOQ. **Please refer to Standard Items Ordering Chart**

SEMI-Standard | Normal lead times, No MOQ

SPECIAL | Extended lead times, Non-stock items, MOQ may be applicable

For a quote, please contact our sales department

GEM-A	BODY	PORT	FUNCTION	ORIFICE	SEALS	MANUAL OVERRIDE
Brass 2	1/8" BSP	10	2W NC 1	0.8 1	NBR N	None 0
		11	2W NO 2	1.2 2	FKM V	Plastic ⁽³⁾ 1
	1/4" BSP	20	2WNO ⁽¹⁾ through 2a base	1.6 3	EPDM E	Slot 2
		21		2.0 4	FFKM ⁽²⁾ K	Knob 3
	1/4" NPT	21		2.4 5	PTFE T	
				3.0 6		
				4.0 7		

GEM-A	BODY	PORT	FUNCTION	ORIFICE	SEALS	MANUAL OVERRIDE
SST 3	1/8" BSP	10	2W NC 1	0.8 1	NBR N	None 0
		11	2W NO 2	1.2 2	FKM V	Plastic ⁽³⁾ 1
	1/4" BSP	20	2WNO ⁽¹⁾ through 2a base	1.6 3	EPDM E	Slot 2
		21		2.0 4	FFKM ⁽²⁾ K	Knob 3
	1/4" NPT	21		2.4 5	PTFE T	
				3.0 6		
				4.0 7		

* For available options, please refer to **VOLTAGE & POWER CONSUMPTION** table below

VOLTAGE	POWER	CONNECTOR
No coil 0	No coil 0	None 0
6 1	AC8W 50Hz 1	with 1
12 2	AC8W 60Hz 2	with LED 2
24 3	DC10W 3	with bi-color LED 3
48 4	AC5.5W50Hz 4	flying leads coil 4
110 5	AC5.5W60Hz 5	with 1/2" Hub 5
120 6	AC2.5W 50/60Hz 6	surge protection with LED 6
220 7A	DC5.5W 7	connector with moulded cable 7
230 7	DC3.5W 8	other 9
240 8		
Latch/ other ⁽⁴⁾ 9		

Voltage & Power Consumption

V	AC (W)						DC (W)		
	50 Hz			60 Hz			10	5.5	3.5
6							●	●	●
12	●			●			●	●	●
24	▲	●	●	●	●	●	▲		●
48	●			●			●		
110	●			▲	●		●		
120	●			●			●		
220	●	●	●	●			●		
230	▲	●		●	●				
240	●			●			●		

Available options:

- ▲ STANDARD
- SEMI-STANDARD
- SPECIAL

Example: GEM-A-21015N2-311

GEM-SOL direct operated brass, 1/8" BSP, 2W NC, 2.4 orifice, NBR, slot manual override, 24V AC8W 50Hz with connector

GEM-A - 2 10 1 5 N 2 - 3 1 1

(1) Option 2a: manual override is not available

(2) FFKM O-ring is available only upon request. When ordering FFKM seals, please consult with our technical sales department about O-ring compound

(3) Maximum pressure: 16 bar

(4) For specifying Latch type coil, please refer to GEM-A3P valve - How to Order table

* Note: When ordering without coil, please define what current and pressure rating is needed (DC, AC or ADC), otherwise an ADC valve will be supplied

* To order valves manufactured according to your specific requirements, please contact our technical sales department

SOLENOID VALVES

GEM-SOL | GEM-A

1/8", 1/4" 3 Way NC, NO

Technical Data

Function	3 Way NC, NO
Ports size	1/8" and 1/4" BSP & NPT
Orifice size	See table
Pressure range	<ul style="list-style-type: none"> • See table • Valves for pressure higher than 25 bar cannot be supplied with manual override
Kv (l/min)	See table
Temperature range	Fluid: -10°C to 80°C (no freezing) Ambient: -10°C to 50°C
Materials in contact with media	Manual override: Plastic (Reinforced Nylon), Brass screw or Brass finger knob, Stainless Steel for Stainless Steel valves (1) Plastic manual override: Maximum pressure: 16 bar (2) Manual override is unavailable in 3 Way NO through base applications Main Valve: Brass or Stainless Steel AISI 316 Solenoid Operator: Stainless Steel AISI 300 & 400 series Seals: NBR, FKM, EPDM, FFKM, PTFE
Media	Air, water, oil
Coil voltage	<ul style="list-style-type: none"> • Voltage and power consumption - see table • All Baccara coil voltages are ± 10% of nominal
Standard protection class	IP65 with connector * Option: IP68 (please refer to GEM-BP Coil)

- Latch valves are available upon request
- * Available with a manifold bracket upon request. Please contact our technical sales department



GEM-A | 3 Way
Stainless Steel



GEM-A | 3 Way
Brass

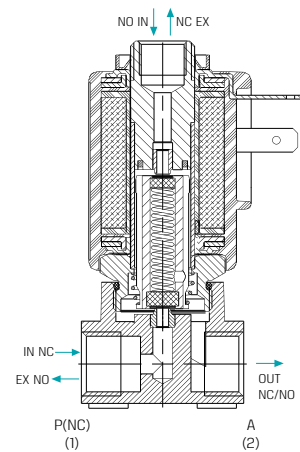

Max. Pressure (bar) 3 Way NC

Coil Current/Power	Orifice (mm)					
	0.8	1.2	1.6	2.0	2.4	3.0
ADC *	23	20	15	10	8	5.5
AC8W, DC10W	35	30	17	14	10	6
AC5.5W	23	20	15	10	8	5.5
AC2.5W DC5.5W DC3.5W	20	16	10	9	5	4
Flow factor Kv(l/min)	0.6	1.1	1.7	2.5	3.5	4.5

Max. Pressure (bar) 3 Way NO

Coil Current/Power	Orifice (mm)					
	0.8	1.2	1.6	2.0	2.4	3.0
ADC *	25	20	15	11	8	6
AC/8W DC/10W	30	22	17	12	10	7
AC/5.5W,DC/5.5W	25	20	15	11	8	6
AC/2.5W,DC/3.5W	20	18	12	8	6	4
Flow factor Kv(l/min)	0.6	1	1.4	2.2	3.0	3.5

* ADC valves are only suitable for use with AC8W or DC10W coils.

Dimensions

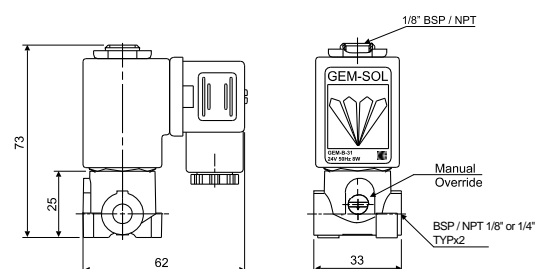
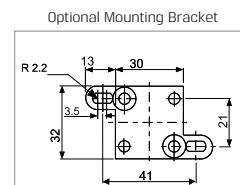
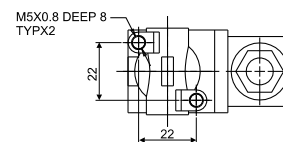

Three Product Ordering Categories available

STANDARD | Reduced lead times, No MOQ

SEMI-STANDARD | Normal lead times, No MOQ

SPECIAL | Extended lead times, Non-stock items, MOQ may be applicable

Ordering Chart

Standard items | Reduced lead times, No MOQ
ADC operator only

MODEL	PORT	FUNCTION	ORIFICE (mm)	SEAL MATERIAL	MANUAL OVERRIDE	CONNECTOR	MOPD (bar)	PART NO. PER VOLTAGE & POWER			
								*Standard coils are not vacuum impregnated			
								24VDC 10W	24VAC 8W 50Hz	110VAC 8W 60Hz	230VAC 8W 50Hz
GEM-A	BRASS	3W NC	1.6	NBR	Slot	with	15	1253088030 GEM-A-21033N2-331 ADC	1253088201 GEM-A-21033N2-311 ADC	1253088202 GEM-A-21033N2-521 ADC	1253088203 GEM-A-21033N2-711 ADC
			2.0				1253090201 GEM-A-21034N2-331 ADC	1253090202 GEM-A-21034N2-311 ADC	1253090203 GEM-A-21034N2-521 ADC	1253090204 GEM-A-21034N2-711 ADC	
			2.4				1253093201 GEM-A-21035N2-331 ADC	1253093202 GEM-A-21035N2-311 ADC	1253093203 GEM-A-21035N2-521 ADC	1253093204 GEM-A-21035N2-711 ADC	
			1.6				1253088204 GEM-A-21133N2-331 ADC	1253088205 GEM-A-21133N2-311 ADC	1253088206 GEM-A-21133N2-521 ADC	1253088207 GEM-A-21133N2-711 ADC	
			2.0				1253090205 GEM-A-21134N2-331 ADC	1253090206 GEM-A-21134N2-311 ADC	1253090632 GEM-A-21134N2-521 ADC	1253090207 GEM-A-21134N2-711 ADC	
			2.4				1253093205 GEM-A-21135N2-331 ADC	1253093206 GEM-A-21135N2-311 ADC	1253093207 GEM-A-21135N2-521 ADC	1253093208 GEM-A-21135N2-711 ADC	
	3W NO	1.6	1253127251 GEM-A-21043N2-331 ADC				1253127536 GEM-A-21043N2-311 ADC	1253127252 GEM-A-21043N2-521 ADC	1253127587 GEM-A-21043N2-711 ADC		
		2.0	1253130201 GEM-A-21044N2-331 ADC				1253130202 GEM-A-21044N2-311 ADC	1253130203 GEM-A-21044N2-521 ADC	1253130204 GEM-A-21044N2-711 ADC		
		2.4	1253138201 GEM-A-21045N2-331 ADC				1253138202 GEM-A-21045N2-311 ADC	1253138203 GEM-A-21045N2-521 ADC	1253138204 GEM-A-21045N2-711 ADC		
		1.6	1253127253 GEM-A-21143N2-331 ADC				1253127254 GEM-A-21143N2-311 ADC	1253127556 GEM-A-21143N2-521 ADC	1253127255 GEM-A-21143N2-711 ADC		
		2.0	1253130205 GEM-A-21144N2-331 ADC				1253130206 GEM-A-21144N2-311 ADC	1253130207 GEM-A-21144N2-521 ADC	1253130208 GEM-A-21044N2-711 ADC		
		2.4	1253138042 GEM-A-21145N2-331 ADC				1253138205 GEM-A-21145N2-311 ADC	1253138206 GEM-A-21145N2-521 ADC	1253138207 GEM-A-21145N2-711 ADC		
	3W NC	1.6	1255088333 GEM-A-22033N2-331 ADC				1255088202 GEM-A-22033N2-311 ADC	1255088203 GEM-A-22033N2-521 ADC	1255088204 GEM-A-22033N2-711 ADC		
		2.0	1255091030 GEM-A-22034N2-331 ADC				1255091202 GEM-A-22034N2-311 ADC	1255091203 GEM-A-22034N2-521 ADC	1255091204 GEM-A-22034N2-711 ADC		
		2.4	1255093030 GEM-A-22035N2-331 ADC				1255093202 GEM-A-22035N2-311 ADC	1255093203 GEM-A-22035N2-521 ADC	1255093204 GEM-A-22035N2-711 ADC		
		1.6	1255088032 GEM-A-22133N2-331 ADC				1255088352 GEM-A-22133N2-311 ADC	1255088205 GEM-A-22133N2-521 ADC	1255088382 GEM-A-22133N2-711 ADC		
		2.0	1255091205 GEM-A-22134N2-331 ADC				1255091206 GEM-A-22134N2-311 ADC	1255091207 GEM-A-22134N2-521 ADC	1255091208 GEM-A-22134N2-711 ADC		
		2.4	1255093205 GEM-A-22135N2-331 ADC				1255093206 GEM-A-22135N2-311 ADC	1255093207 GEM-A-22135N2-521 ADC	1255093208 GEM-A-22135N2-711 ADC		
		3W NO	1.6				1255127201 GEM-A-22043N2-331 ADC	1255127530 GEM-A-22043N2-311 ADC	1255127203 GEM-A-22043N2-521 ADC	1255127580 GEM-A-22043N2-711 ADC	
			2.0				1255130030 GEM-A-22044N2-331 ADC	1255130530 GEM-A-22044N2-311 ADC	1255130203 GEM-A-22044N2-521 ADC	1255130581 GEM-A-22044N2-711 ADC	
			2.4				1255138201 GEM-A-22045N2-331 ADC	1255138202 GEM-A-22045N2-311 ADC	1255138203 GEM-A-22045N2-521 ADC	1255138204 GEM-A-22045N2-711 ADC	
			1.6				1255127032 GEM-A-22143N2-331 ADC	1255127534 GEM-A-22143N2-311 ADC	1255127207 GEM-A-22143N2-521 ADC	1255127584 GEM-A-22143N2-711 ADC	
			2.0				1255130205 GEM-A-22144N2-331 ADC	1255130533 GEM-A-22144N2-311 ADC	1255130207 GEM-A-22144N2-521 ADC	1255130208 GEM-A-22144N2-711 ADC	
			2.4				1255138205 GEM-A-22145N2-331 ADC	1255138206 GEM-A-22145N2-311 ADC	1255138207 GEM-A-22145N2-521 ADC	1255138208 GEM-A-22145N2-711 ADC	

(continued on next page)

SOLENOID VALVES

GEM-SOL | GEM-A

1/8", 1/4" 3 Way NC, NO

Ordering Chart

Standard items | Reduced lead times, No MOQ
ADC operator only

MODEL	PORT	FUNCTION	ORIFICE (mm)	SEAL MATERIAL	MANUAL OVERRIDE	CONNECTOR	MOPD (bar)	PART NO. PER VOLTAGE & POWER			
								24VDC 10W	24VAC 8W 50Hz	110VAC 8W 60Hz	230VAC 8W 50Hz
GEM-A SST	1/4" BSP	3W NC	1.6	FKM	Slot	with	15	1255088211 GEM-A-32033V2-331 ADC	1255088212 GEM-A-32033V2-311 ADC	1255088213 GEM-A-32033V2-521 ADC	1255088214 GEM-A-32033V2-711 ADC
			2.0				10	1255091211 GEM-A-32034V2-331 ADC	1255091212 GEM-A-32034V2-311 ADC	1255091213 GEM-A-32034V2-521 ADC	1255091214 GEM-A-32034V2-711 ADC
			2.4				8	1255093211 GEM-A-32035V2-331 ADC	1255093212 GEM-A-32035V2-311 ADC	1255093213 GEM-A-32035V2-521 ADC	1255093214 GEM-A-32035V2-711 ADC
			1.6				15	1255088215 GEM-A-32133V2-331 ADC	1255088216 GEM-A-32133V2-311 ADC	1255088217 GEM-A-32133V2-521 ADC	1255088218 GEM-A-32033V2-711 ADC
			2.0				10	1255091215 GEM-A-32034V2-331 ADC	1255091216 GEM-A-32134V2-311 ADC	1255091217 GEM-A-32134V2-521 ADC	1255091218 GEM-A-32134V2-711 ADC
			2.4				8	1255093215 GEM-A-32135V2-331 ADC	1255093216 GEM-A-32135V2-311 ADC	1255093217 GEM-A-32135V2-521 ADC	1255093218 GEM-A-32135V2-711 ADC
	1/4" BSP	3W NO	1.6				15	1255127211 GEM-A-32043V2-331 ADC	1255127074 GEM-A-32043V2-311 ADC	1255127213 GEM-A-32043V2-521 ADC	1255127214 GEM-A-32043V2-711 ADC
			2.0				11	1255130211 GEM-A-32044V2-331 ADC	1255130212 GEM-A-32044V2-311 ADC	1255130213 GEM-A-32044V2-521 ADC	1255130214 GEM-A-32044V2-711 ADC
			2.4				8	1255138049 GEM-A-32045V2-331 ADC	1255138212 GEM-A-32045V2-311 ADC	1255138213 GEM-A-32045V2-521 ADC	1255138214 GEM-A-32045V2-711 ADC
			1.6				15	1255127149 GEM-A-32143V2-331 ADC	1255127215 GEM-A-32143V2-311 ADC	1255127216 GEM-A-32143V2-521 ADC	1255127217 GEM-A-32143V2-711 ADC
			2.0				11	1255130215 GEM-A-32144V2-331 ADC	1255130216 GEM-A-32144V2-311 ADC	1255130217 GEM-A-32144V2-521 ADC	1255130218 GEM-A-32144V2-711 ADC
			2.4				8	1255138215 GEM-A-32145V2-331 ADC	1255138216 GEM-A-32145V2-311 ADC	1255138217 GEM-A-32145V2-521 ADC	1255138218 GEM-A-32145V2-711 ADC

Model Selection

- STANDARD** | Reduced lead times, No MOQ. Please refer to **Standard Items Ordering Chart**
- SEMI-STANDARD** | Normal lead times, No MOQ
- SPECIAL** | Extended lead times, Non-stock items, MOQ may be applicable. For a quote, please contact our sales department

* For available options, please refer to **VOLTAGE & POWER CONSUMPTION** table below

GEM-A	BODY	PORT	FUNCTION	ORIFICE	SEALS	MANUAL OVERRIDE
Brass	2	1/8" BSP 10	3W NC 3	0.8 1	NBR N	None 0
		1/8" NPT 11	3W NO 4	1.2 2	FKM V	Plastic (3) 1
	20	1/4" BSP	3WNO (1) through 4a base	1.6 3	EPDM E	Slot 2
				2.0 4	FFKM (2) K	Knob 3
				2.4 5	PTFE T	
				3.0 6		

GEM-A	BODY	PORT	FUNCTION	ORIFICE	SEALS	MANUAL OVERRIDE
SST	3	1/8" BSP 10	3W NC 3	0.8 1	NBR N	None 0
		1/8" NPT 11	3W NO 4	1.2 2	FKM V	Plastic (3) 1
	20	1/4" BSP	3WNO (1) through 4a base	1.6 3	EPDM E	Slot 2
				2.0 4	FFKM (2) K	Knob 3
				2.4 5	PTFE T	
				3.0 6		

VOLTAGE	POWER	CONNECTOR
No coil 0	No coil 0	None 0
6 1	AC8W 50Hz 1	with 1
12 2	AC8W 60Hz 2	with LED 2
24 3	DC10W 3	with bi-color LED 3
48 4	AC5.5W/50Hz 4	flying leads coil 4
110 5	AC5.5W/60Hz 5	with 1/2" Hub 5
120 6	AC2.5W/50/60Hz 6	surge protection with LED 6
220 7A	DC5.5W 7	connector with moulded cable 7
230 7	DC3.5W 8	other 9
240 8		
Latch/other(4) 9		

Voltage & Power Consumption

V	AC (W)						DC (W)		
	50 Hz			60 Hz			10	5.5	3.5
6							●	●	●
12	●			●			●	●	●
24	▲	●	●	●	●	●	▲		●
48	●			●			●		
110	●			▲	●		●		
120	●			●					
220	●	●	●	●			●		
230	▲	●		●	●				
240	●			●			●		

Available options:
 ▲ STANDARD
 ● SEMI-STANDARD
 ■ SPECIAL

Example: GEM-A-21035N2-311

GEM-SOL direct operated brass, 1/8" BSP, 3W NC, 2.4 orifice, NBR, slot manual override, 24V AC8W 50Hz with connector

GEM-A - 2 - 10 - 3 - 5 - N - 2 - 3 - 1 - 1

- (1) Option 4a: manual override is not available
 (2) FFKM O-ring is available only upon request. When ordering FFKM seals, please consult with our technical sales department about O-ring compound
 (3) Maximum pressure: 16 bar
 (4) For specifying Latch type coil, please refer to GEM-A3P valve - How to Order table

* Note: When ordering without coil, please define what current and pressure rating is needed (DC, AC or ADC), otherwise an ADC valve will be supplied

* To order valves manufactured according to your specific requirements, please contact our technical sales department

SOLENOID VALVES

GEM-SOL | GEM-A3P

Latch 3 Positioning Manual Override, 2 Way, 3 Way NC, NO

Technical Data

Function	2 Way, 3 Way NC, NO
Ports size	1/8" and 1/4" BSP & NPT
Orifice size	See table
Pressure range	See table
Kv (l/min)	See table
Temperature range	Fluid: -10°C to 80°C (no freezing) Ambient: -10°C to 50°C
Materials in contact with media	Manual override: Plastic (Reinforced Nylon) Main Valve: Brass Solenoid Operator: Stainless Steel AISI 300 & 400 series Seals: NBR, FKM, EPDM, FFKM
Media	Air, water, oil
Coil type	Latch
Standard protection class	IP65 with connector * Option: IP68 (please refer to GEM-BP Coil)

* Available with a manifold bracket upon request.
Please contact our technical sales department



Max. Pressure (bar) 2 Way NC

Orifice (mm)	0.8	1.2	1.6	2.0	2.4	3.0	4.0
Pressure (bar)	16	16	16	16	16	16	8
Flow factor Kv(l/min)	0.5	1.1	1.7	2.5	3.5	4.5	5

Max. Pressure (bar) 2 Way NC

Orifice (mm)	0.8	1.2	1.6	2.0	2.4	3.0
Pressure (bar)	16	16	16	16	15	10
Flow factor Kv(l/min)	0.5	1.1	1.7	2.5	3.5	4.5

Max. Pressure (bar) 2 Way NC

Orifice (mm)	0.8	1.2	1.6	2.0	2.4	3.0
Pressure (bar)	16	16	16	14	9	5
Flow factor Kv(l/min)	0.5	1.1	1.7	2.5	3.5	4.5

Max. Pressure (bar) 3 Way NO

Orifice (mm)	0.8	1.2	1.6	2.0	2.4	3.0
Pressure (bar)	16	16	16	12	10	7
Flow factor Kv(l/min)	0.5	1.1	1.7	2.5	3.5	4.5

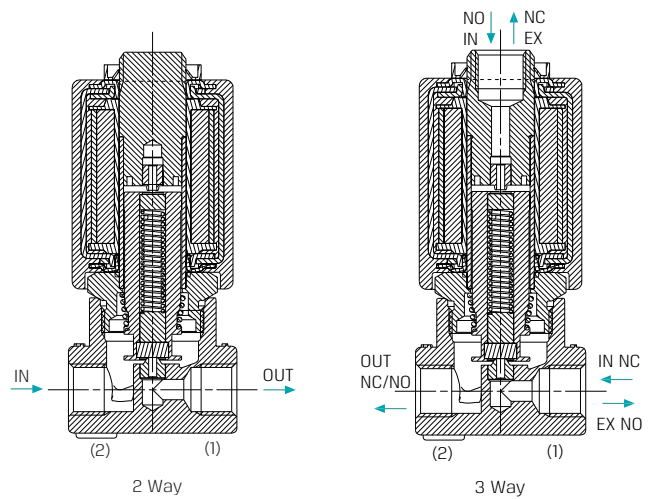

Dimensions

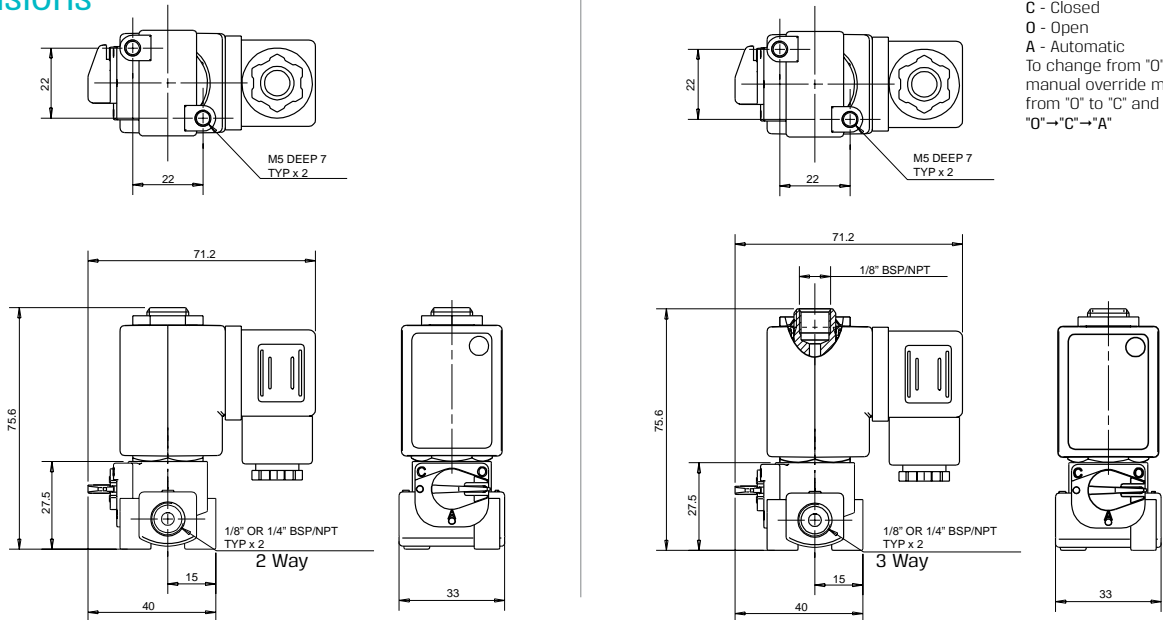

Note:
 C - Closed
 O - Open
 A - Automatic
 To change from "O" to "A", the manual override must be turned from "O" to "C" and then to "A":
 "O" → "C" → "A"

How to Order

GEM-A3P	BODY	PORT	FUNCTION	ORIFICE	SEALS	LATCH TYPE ⁽¹⁾	CONNECTOR							
-	Brass	2	1/8" BSP	10	2W NC	1	0.8	1	NBR	N	2Ω	LDO	without	0
			1/8" NPT	11	2W NO	2	1.2	2	FKM	V	5Ω	IL	with	1
		1/4"	BSP	20	3W NC	3	1.6	3	EPDM	E	13Ω	EL	with 1/2" Hub	5
			NPT	21	3W NO	4	2.0	4	FFKM	K	20Ω	OL	connector with moulded cable	7
							2.4	5			53Ω	DL	other	9
							3.0	6						
							4.0	7						

Example: GEM-A3P-21015N-LD01

GEM-SOL latch 3 positioning manual override, brass, 1/8" BSP, 2W NC, 2.4 orifice, NBR, 2 latch with connector

GEM-A3P - 2 10 1 5 N - LDO 1

(1) Choose latch type according to which latch system you have

* To order valves manufactured according to your specific requirements, please contact our technical sales department

b **BACCARA**[®]
AUTOMATION & CONTROL



SOLENOID MANIFOLDS

GEM-FLOW | G75-VM

Modular Manifold 30



SOLENOID MANIFOLDS

GEM-FLOW | G75-VM

Modular Manifold

Technical Data

Function	3 Way NC, NO
Orifice size	1.8 mm
Pressure range	0 to 8 bar
Temperature range	Fluid: 0°C to 50°C (no freezing) Ambient: -10°C to 50°C
Materials in contact with media	Manual override: Plastic (Reinforced Nylon) Main Valve: Plastic (Reinforced Nylon & POM) Solenoid Operator: Stainless Steel AISI 300 & 400 series Seals: EPDM
Mounting	With bracket
Modular connection type	Thread type connection
Modular connection assembly recommendation	<ul style="list-style-type: none"> Manually tighten one station to another Using tools and/or excessive torques may lead to irreversible damage
Manual override	Latch: 3 position latch: Auto, Close, Open AC: 2 position: Auto, Open
Media	Air, water
Coil voltage	Latch, AC (according to table)
Standard protection class	IP66

* Can **only** be operated with supplied coil



PORT	NO	NC
1	Exhaust	Pressure
3	Pressure	Exhaust
COM	Out	Out

Voltage & Current

AC & DC

Solenoid	Inrush [A]	Holding [A]
24VAC-50 Hz	0.33	0.21

Latch Coil Resistance vs Input Voltage

Recommendations chart

Resistance [Ω]	Input voltage range [V]
4	6 - 9
9	12 - 14
12	14 - 16
23	18 - 21

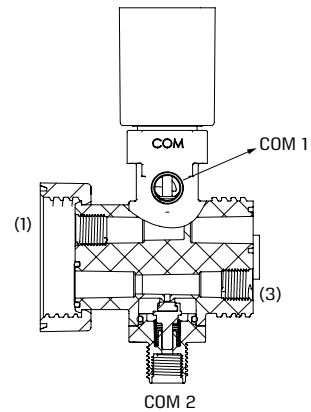

Dimensions

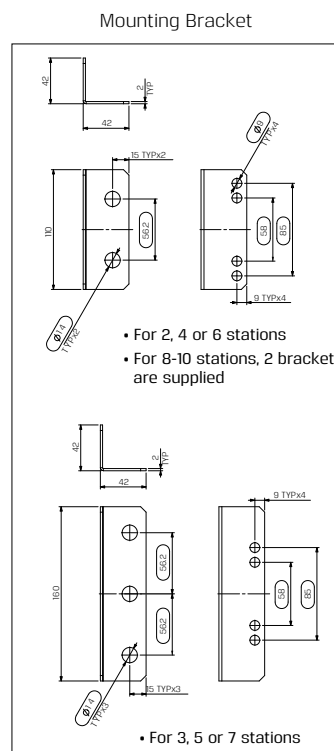
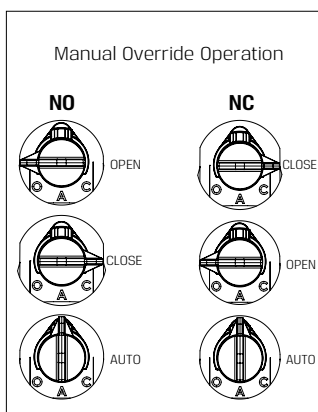
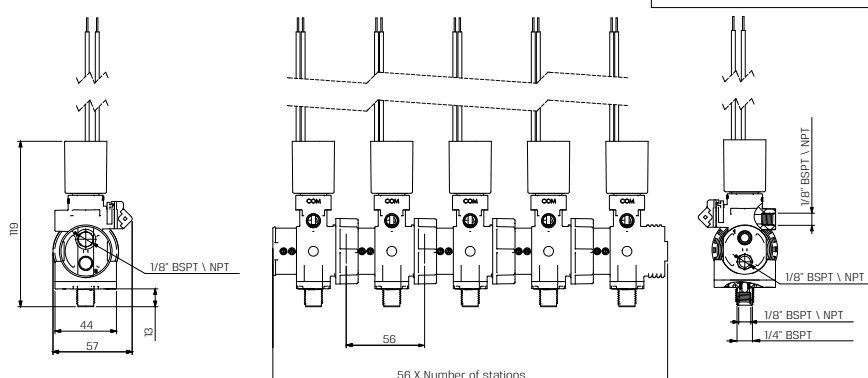

How to Order | Manifold

G75-VM	No. OF STATIONS ⁽¹⁾	BODY	PORT	FUNCTION	MANUAL OVERRIDE	ORIFICE	SEALS	TYPE	MOUNTING BRACKET	OUTLET ⁽⁴⁾	WIRES
	Specify quantity: 2 - 10	Plastic 4	1/8" BSPT 10	3W NC 3	Plastic 1	1.8 3a	EPDM E	24VAC-50Hz ⁽²⁾	S1	COM 1 1	two Null
			1/8" NPT 11	3W NO 4				4Ω ⁽³⁾	SB	COM 2 2	three ⁽⁵⁾ a
								9Ω ⁽³⁾	SC		
								12Ω ⁽³⁾	SD		
								23Ω ⁽³⁾	S6		

Example: G75-VM-3410313aE-SB11

G75-VM manifold, 3 stations, plastic, 1/8" BSPT, 3W NC, plastic manual override, 1.8 orifice, EPDM seals, 4Ω latch, with mounting bracket, COM 1 outlet, two wires

G75-VM - 3 4 10 3 1 3a E - SB 1 1

(1) Manifold designed for a maximum of 10 stations, the use of more will reduce the outlet flow rate to all

(2) Refer to Voltage & Current AC & DC

(3) Refer to Latch Coil Resistance vs Input Voltage | Recommendations chart

(4) A plug will be fitted on the other outlet port

(5) Latch only

How to Order | Manifold Components

G75-VM	TYPE	BODY	PORT	FUNCTION	MANUAL OVERRIDE	ORIFICE	SEALS	TYPE	OUTLET ⁽³⁾	WIRES	
	Left L	Plastic 4	1/8" BSPT 10	3W NC 3	Plastic 1	1.8 3a	EPDM E	24VAC-50Hz ⁽¹⁾	S1	COM 1 1	two Null
	Right R		1/8" NPT 11	3W NO 4				4Ω ⁽²⁾	SB	COM 2 2	three ⁽⁴⁾ a
	Middle M							9Ω ⁽²⁾	SC		
								12Ω ⁽²⁾	SD		
								23Ω ⁽²⁾	S6		

Example: G75-VM-L410313aE-SB1

G75-VM Left component, plastic, 1/8" BSPT, 3W NC, plastic manual override 1.8 orifice, EPDM seals, 4Ω latch, COM 1 outlet, two wires

G75-VM - L 4 10 3 1 3a E - SB 1

(1) Refer to Voltage & Current AC & DC

(2) Refer to Latch Coil Resistance vs Input Voltage | Recommendations chart

(3) A plug will be fitted on the other outlet port

(4) Latch only

* To order manifolds manufactured according to your specific requirements, please contact our technical sales department

b **BACCARA**[®]
AUTOMATION & CONTROL



ISOLATED / FERTILIZER

SOLENOIDS

GEM-SOL GEM-CPR	Precise Isolated Proportional 2 Way NC	34
GEM-SOL GEM-C	Chem-Sol 1/4" 2 Way NC, NO.....	36
GEM-SOL GEM-C	Chem-Sol 1/2" 2 Way NC.....	38



ISOLATED/FERTILIZER SOLENOIDS

GEM-SOL | GEM-CPR

Precise Isolated Proportional 2 Way NC



Technical Data

Function	2 Way NC (with back-up battery)
Ports size	1/2" BSP & NPT
Orifice size	8mm (Up to 600 l/hour)
Pressure range	<ul style="list-style-type: none"> • Vacuum applications: (-) - 0 Bar • Pressure applications: 0 - (+) Bar *For other pressures, please consult our technical sales department
Temperature range	Fluid: -10° to 45°C (no freezing) Ambient: -10°C to 45°C
Materials	In contact with media: Valve body: <ul style="list-style-type: none"> • Standard: PVC (UV Protection) • Optional: According to customer demand or application (e.g Stainless steel) Diaphragm & seals: FKM, EPDM Not in contact with media: Operator housing: PP (UV protection) Manual override: Acetal (Manual override is standard)
Media	<ul style="list-style-type: none"> • Liquids & Gases *Please consult our technical sales department for a specific media Application examples: <ul style="list-style-type: none"> • Irrigation fertilizing systems • Medical devices
Control signal	0-5V or 4-20mA
Valve stroke resolution	< 0.01mm
Valve stroke accuracy	< ± 0.01 mm
Full stroke duration	0.6 sec, each direction
Current consumption	<ul style="list-style-type: none"> • Standby Mode (Holding position): 25 [mA] • Active Control Mode: Up to 120 [mA] • Full Open/Close Mode (starting current): Up to 600 [mA]
Supply voltage	12-24 [V] ±5% AC (50 or 60Hz) Or 12-24[V] ±10% DC *For other supply voltages, please consult our technical sales department *Current and voltage spikes protections might be required. Please consult our technical sales department
Connection	5 wires cable (3m length): <ul style="list-style-type: none"> • Black & red: Supply voltage (polarity is not restricted) • Green: 0-5 V analog control signal • Blue: 4-20 mA analog control signal • Yellow: Analog control signal common
Recommended control signal resolution	Voltage: 20 mV Current: 0.064 mA
Standard / Certification	CE <ul style="list-style-type: none"> • EMC: EN55011 Group 1 - Class A EN61000-6-1 CFR 47 FCC Class A • SAFETY: IEC/EN61010-1
Standard protection class	IP67



Typical Performance Graph

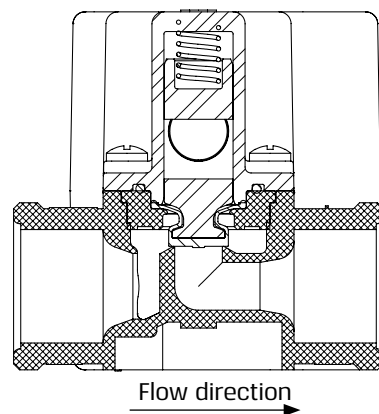
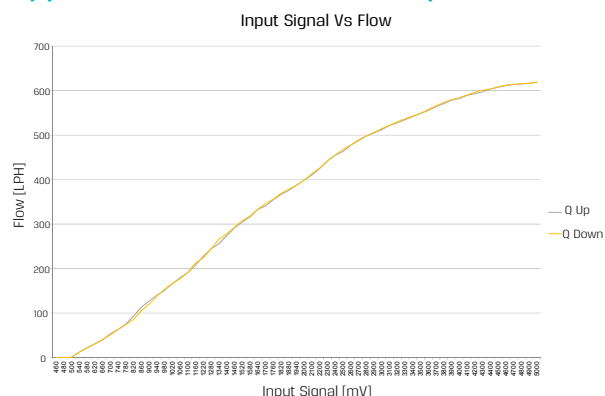

Dimensions

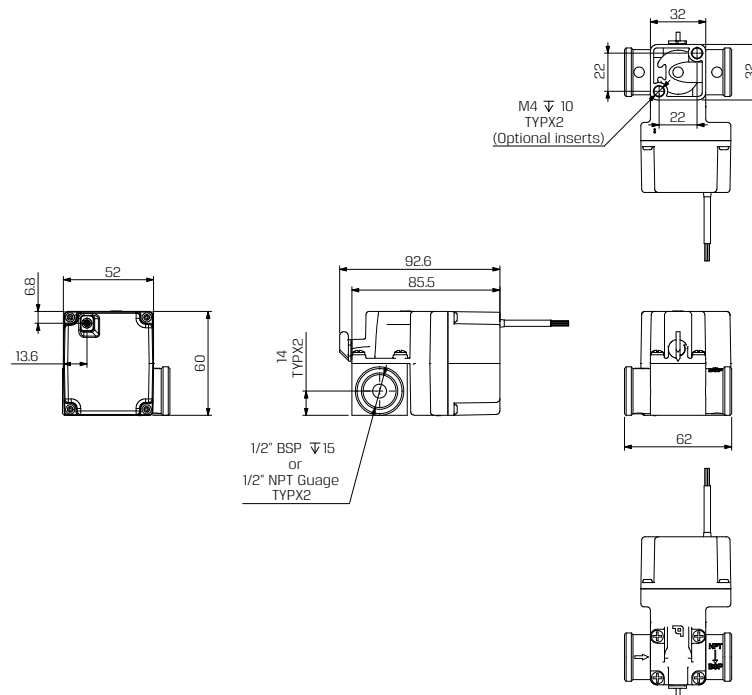

How to Order

GEM-CPR	PORT	FUNCTION	PRESSURE	SEALS	MANUAL OVERRIDE	CONTROL SIGNAL	VOLTAGE
1/2" BSP	40	2W NC 1	Vacuum 1	FKM V	Plastic 1	0-5 V 1	12-24 VDC 1
1/2" NPT	41		Pressure ⁽¹⁾ 2	EPDM E		4-20 mA 2	12-24 VAC 2

Example: GEM-CPR-4011E1-11

Precise Isolated proportional valve, 1/2" BSP, 2W NC, Vacuum, EPDM seals, plastic manual override with 0-5V control signal, 12-24VDC

GEM-CPR - 40 1 1 E 1 - 1 1

(1) Maximum inlet pressure: 1 bar

* Please specify the working pressure range when placing an order

* To order valves manufactured according to your specific requirements, please contact our technical sales department

ISOLATED/FERTILIZER SOLENOIDS

GEM-SOL | GEM-C

Chem-Sol 1/4" 2 Way NC, NO

Technical Data

Function	2 Way NC, NO
Ports size	1/4" BSP & NPT
Orifice size	4.5mm * Option for 2.8 mm orifice. Please contact our technical sales department
Pressure range	See table
Kv (l/min)	5 l/min
Temperature range	Fluid: 5° to 50°C (no freezing) Ambient: -10°C to 50°C
Materials in contact with media	Manual override: NC: Plastic (Reinforced Nylon) NO: Manual override is not available Main Valve: Reinforced PPA Seals: FKM, EPDM, Silicone
Applications	<ul style="list-style-type: none"> • Chemical process • Water treatment • Analysis device etc
Coil voltage	<ul style="list-style-type: none"> • Voltage and power consumption - see table • All Baccara coil voltages are ± 10% of nominal
Standard protection class	IP65 with connector * Option: IP68 (please refer to GEM-BP coil)



Pressure (bar) NC

Coil	Flow direction not restricted	Flow direction restricted
ADC *	0 to 2.5 bar	0 to 0.6 bar
AC 8W	0 to 2.5 bar	0 to 0.7 bar
AC 5.5W	0 to 2 bar	0 to 0.5 bar
DC 5.5W	0 to 1.5 bar	0 to 0.4 bar

Vacuum (bar) NC

Coil	Flow direction not restricted	minimum Δp
ADC *	-1 to 0 bar	1 bar
AC 5.5W	-1 to 0 bar	
DC 5.5W	-1 to 0 bar	

Pressure (bar) NO

Coil & power rating	Flow direction not restricted	Flow direction restricted ⁽¹⁾
ADC*, AC 8W or DC10W	0 to 1 bar	0 to 0.5 bar
5.5W AC/DC	0 to 1 bar	0 to 0.5 bar

(1) Higher input pressure of up to 1atm can be achieved with minimal pressure drop on the valve of 0.3atm

* ADC valves are only suitable for use with AC8W or DC10W coils.

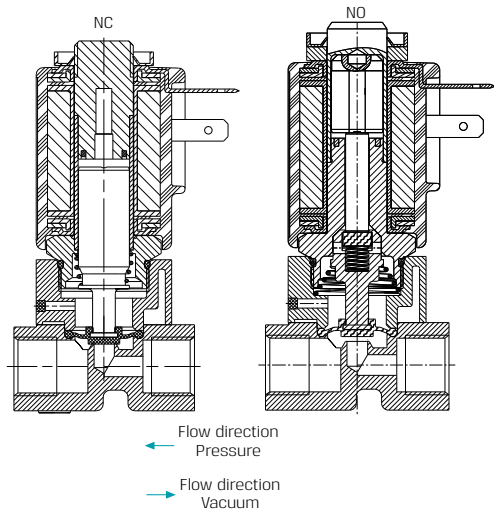

Voltage & Power Consumption

V	AC (W)						DC (W)		
	50 Hz			60 Hz			10	5.5	3.5
6							•	•	
12	•			•			•	•	
24	•	•		•	•		•		
48	•			•			•		
110	•			•	•		•		
120	•			•					
220	•	•		•			•		
230	•	•		•	•				
240	•			•			•		

• Available options

• Available options

Dimensions

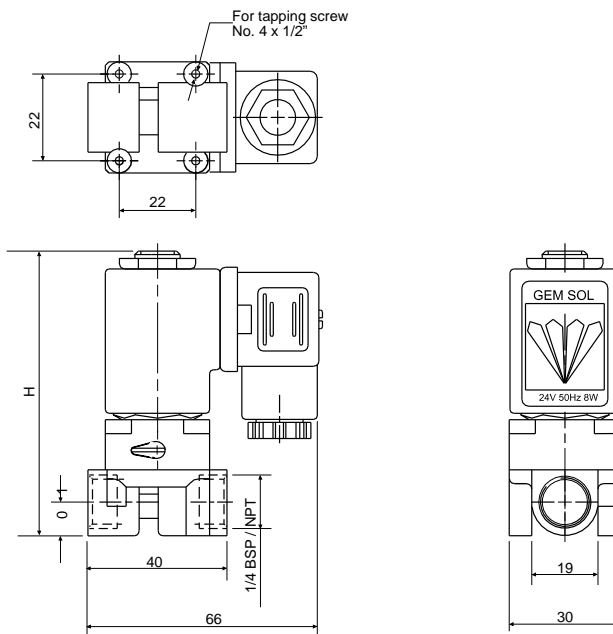

Notes

Type	Valve Description	H
NC	GEM-C-12 □1...	81
NO	GEM-C-12 □2...	84.5

How to Order

GEM-C	BODY	PORT	FUNCTION	PRESSURE	SEALS	MANUAL OVERRIDE ⁽¹⁾	VOLTAGE	POWER	CONNECTOR							
Plastic	1	1/4" BSP	2W NC	1	Vacuum	1	FKM	V	None	0	W/out coil	0	without	0		
		1/4" NPT	2W NO	2	Pressure	2	EPDM	E	Plastic	1	6	1	AC8W 50Hz	1	with	1
					Silicone	S					12	2	AC8W 60Hz	2	with LED	2
											24	3	DC10W	3	with bi-color LED	3
											48	4	AC5.5W 50Hz	4	flying leads coil	4
											110	5	AC5.5W 60Hz	5	with 1/2" Hub	5
											120	6	DC5.5W	7	surge protection with LED	6
											220	7A			connector with moulded cable	7
											230	7			other	9
											240	8				
											Latch/other ⁽²⁾	9				

Example: GEM-C-12012V1-321

GEM-SOL Chem-Sol, PPA, 1/4"BSP, 2W NC, Pressure, FKM, plastic manual override, 24V AC 8W 60 Hz with connector

GEM-C - 1 20 1 2 V 1 - 3 2 1

(1) NO - manual override is not available

(2) For specifying Latch type coil, please refer to GEM-A3P valve - How to Order table

* Note: When ordering without coil, please define what current and pressure rating is needed (DC, AC or ADC), otherwise an ADC valve will be supplied

* To order valves manufactured according to your specific requirements, please contact our technical sales department

ISOLATED/FERTILIZER SOLENOIDS

GEM-SOL | GEM-C

Chem-Sol 1/2" 2 Way NC

Technical Data

Function	2 Way NC
Ports size	1/2" BSP & NPT
Orifice size	8mm
Pressure range	See table
Kv (l/min)	18 l/min
Temperature range	Fluid: 5°C to 50°C (no freezing) Ambient: -10°C to 50°C
Materials in contact with media	Manual override: Plastic (Reinforced Nylon) * Available for vacuum application only Main Valve: PVC Seals: FKM, EPDM
Applications	<ul style="list-style-type: none"> • Chemical process • Water treatment • Analysis device etc
Coil voltage	<ul style="list-style-type: none"> • Voltage and power consumption - see table • All Baccara coil voltages are from -5% to ±10% of nominal
Standard protection class	IP65 with connector * Option: IP68 (please refer to GEM-BP coil)

- Supplied with mounting threads on request, please specify



Pressure (bar) NC

Coil	Flow direction not restricted	Flow direction restricted
AC 8W, DC10W	0 to 0.7 bar	Min dp 0.3 bar

Vacuum (bar) NC

Coil	Flow direction not restricted	Flow direction restricted
AC 8W	-1 to 0.5 bar	-1 to 0.5 bar
AC 5.5W	-0.5 to 0.5 bar	-0.8 to 0.5 bar
DC 10W	-0.4 to 0.5 bar	-0.6 to 0.5 bar

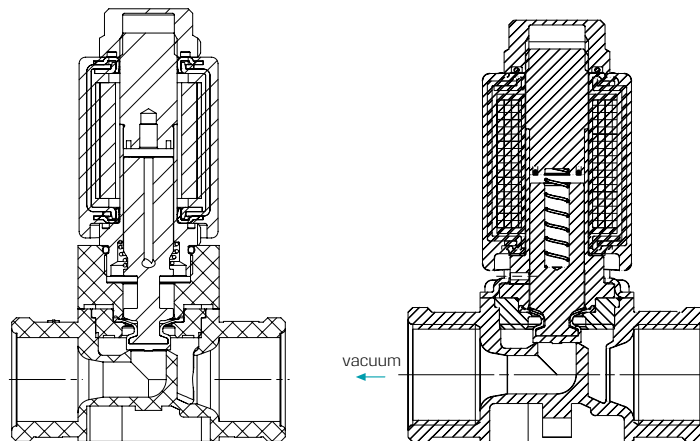

Voltage & Power Consumption

V	AC (W)						DC (W)		
	50 Hz			60 Hz			10	5.5	3.5
6							•	•	
12	•	•		•	•		•	•	
24	•	•	•	•	•		•	•	
48	•	•		•	•		•	•	
110	•	•		•	•		•	•	
120	•	•		•	•				
220	•	•	•	•	•	•	•	•	
230	•	•	•	•	•	•			
240	•	•		•	•		•	•	

Available options:

- Vacuum
- Pressure

Dimensions

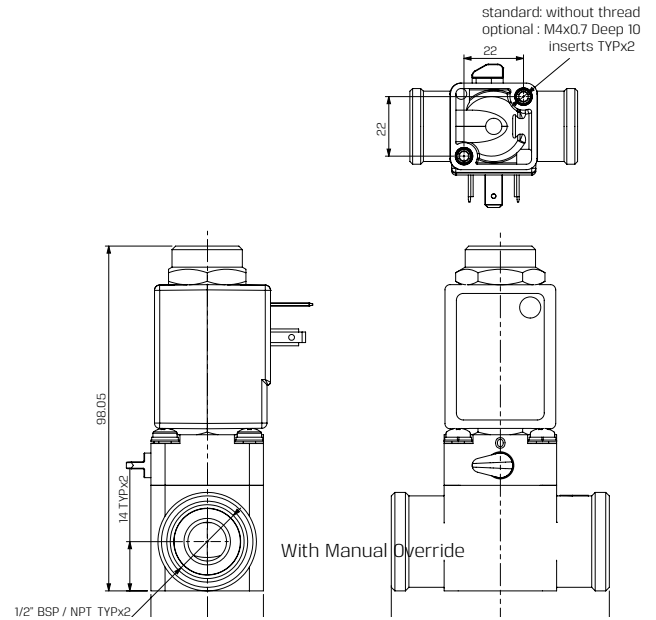
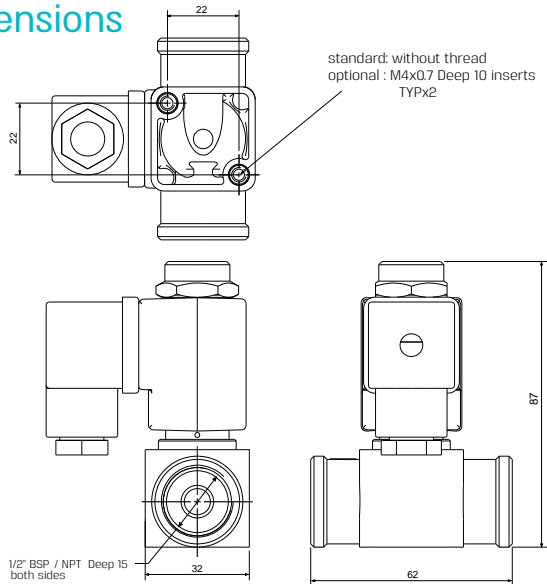

How to Order

GEM-C	PORT	FUNCTION	PRESSURE	SEALS	MANUAL OVERRIDE	VOLTAGE	POWER	CONNECTOR
1/2" BSP	40	2W NC 1	Vacuum 1	FKM V	None Null	W/out coil 0	No coil 0	without 0
1/2" NPT	41		Pressure 2	EPDM E	Plastic ⁽¹⁾ 1	6 1	AC8W 50Hz 1	with 1
						12 2	AC8W 60Hz 2	with LED 2
						24 3	DC10W 3	with bi-color LED 3
						48 4	AC5.5W 50Hz 4	flying leads coil 4
						110 5	AC5.5W 60Hz 5	with 1/2" Hub 5
						120 6		surge protection with LED 6
						220 7A		connector with moulded cable 7
						230 7		other 9
						240 8		
						Latch/other ⁽²⁾ 9		

* When ordering without coil, please define what current and pressure rating is needed (DC, AC)

Example: GEM-C-4011V1-321

GEM-SOL Chem-Sol, 1/2" BSP, 2W NC for vacuum, FKM, plastic manual override, 24V AC 8W 60Hz with connector

GEM-C - 40 - 1 - 1 - V - 1 - 3 - 2 - 1

(1) Available for Vacuum application only

(2) For specifying Latch type coil, please refer to GEM-A3P valve - How to Order table

* To order valves manufactured according to your specific requirements, please contact our technical sales department



ELECTRIC & HYDRAULIC

VALVES

GEM-SOL GEM-S	1/4" - 1" 2 Way NC, NO	42
GEM-SOL GEM-S	1/4" - 1" 2 Way NC, NO	44
GEM-SOL GEM-S	1/4", 1/2" 3 Way NC, NO	46
GEM-SOL GEM-S	Pilot Operated 3/4" - 2" 2 Way NC, NO	48
GEM-SOL GEM-S-4	Upstream Pilot Control Integrated with Gem-Sol Operator 3/4" - 2" 2 Way NC, NO	50
GEM-FLOW G75-S	Pilot Operated 1/2" 2 Way NC	52
GEM-FLOW G75-S	Electric 3/4" - 2" 2 Way NC	54
GEM-SOL GEM-Z	Zero Differential Pressure 1/4" - 3/4" 2 Way NC, NO	56
GEM-FLOW G75-S	Hydraulic 3/4"- 2" 2 Way	58
GEM-FLOW G75-S	3 Way Integral Solenoid Pilot Control 3/4" - 2" NC	60
GEM-FLOW G75-SE	3 Way External Solenoid Pilot Control 3/4" - 2" NC, NO	61
GEM-FLOW G75	3 Way Manual Selector 3/4" - 2" NC, NO	62
GEM-FLOW G75	Pressure Reducing 3/4" - 2" 2 Way NC	63
GEM-FLOW G75-Z	Electric Zero Differential Pressure 3/4" - 2" 2 Way NC	64



ELECTRIC & HYDRAULIC VALVES

GEM-SOL | GEM-S

1/4" - 1" 2 Way NC, NO



Brass | 1/4" | NC



Brass | 1/2" | NO



Stainless Steel | 3/4" | NC



Stainless Steel | 1" | NC

Technical Data

Function	2 Way NC, NO
Ports size	1/4", 3/8", 1/2", 3/4", 1" BSP & NPT
Pressure range	See table * Minimum pressure differential of 0.3 or 0.5 is required
Kv (l/min)	See table
Temperature range	Fluid: -10°C to 80°C (no freezing) Ambient: -10°C to 50°C
Materials in contact with media	Manual override: NC/NO - Brass screw NOa* - manual override is not available *pressure is supplied through the base Main Valve: Brass, Stainless Steel AISI 316 Solenoid Operator: Stainless Steel AISI 300 & 400 series Seals: NBR, FKM, EPDM
Coil voltage	• Voltage and power consumption - see table • All Baccara coil voltages are ± 10% of nominal
Standard protection class	IP65 with connector * Option: IP68 (please refer to GEM-BP Coil)

- Slow closing system to prevent water hammer effect

Voltage & Power Consumption

V	AC (W)						DC (W)		
	50 Hz			60 Hz			10	5.5	3.5
6							•		
12	•			•			•		
24	•			•			•		
48	•			•			•		
110	•			•			•		
120	•			•					
220	•			•			•		
230	•			•	•				
240	•			•			•		

- Available options

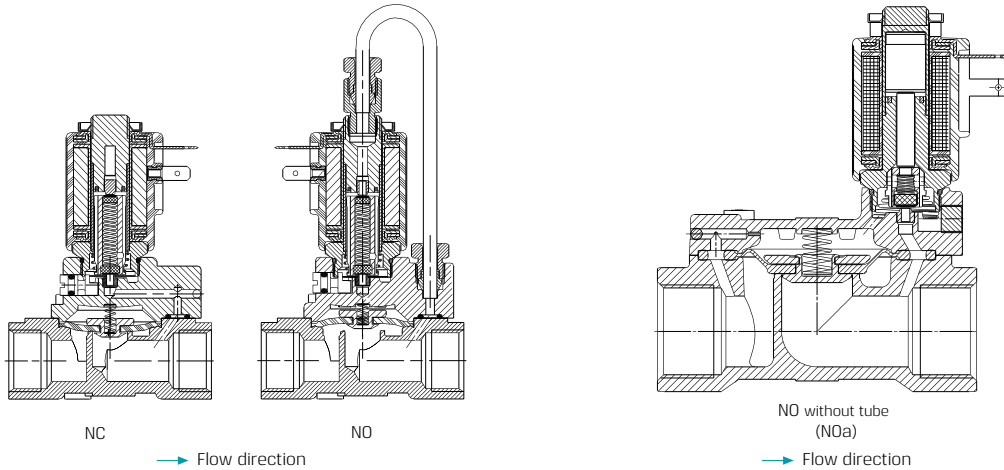

Pressure (bar) & Flow NO/NC GEM-S-□-20...41

Size	Orifice (mm)	Pressure (bar)		Kv (l/min)
		AC, DC	ADC	
1/4"	8	0.5 to 20	0.5 to 15	12
3/8"	8			16
1/2"	12			35

Pressure (bar) & Flow NO/NC GEM-S-□-□r

Size	Orifice (mm)	Pressure (bar)		Kv (l/min)
		AC, DC	ADC	
1/2"	16	0.5 to 20	0.5 to 15	60
3/4"	16			80

Pressure (bar) & Flow NO/NC GEM-S-□-50...60

Port Connection	Orifice (mm)	Pressure range (bar) AC, DC & ADC	Kv (l/min)
3/4"	20	0.3 to 15	130
1"	25	0.5 to 15	200

ELECTRIC & HYDRAULIC VALVES

GEM-SOL | GEM-S

1/4" - 1" 2 Way NC, NO

Dimensions

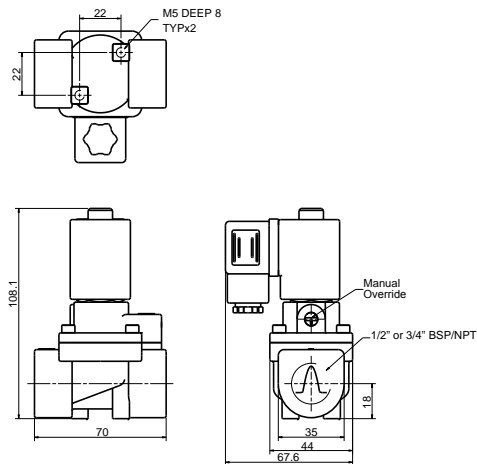
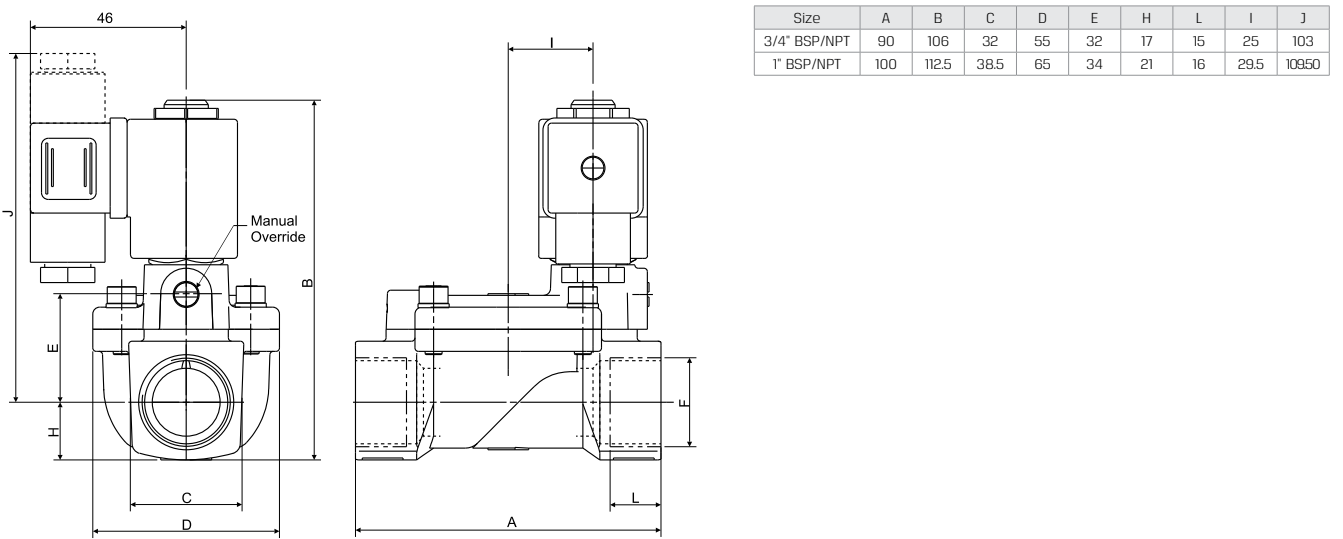
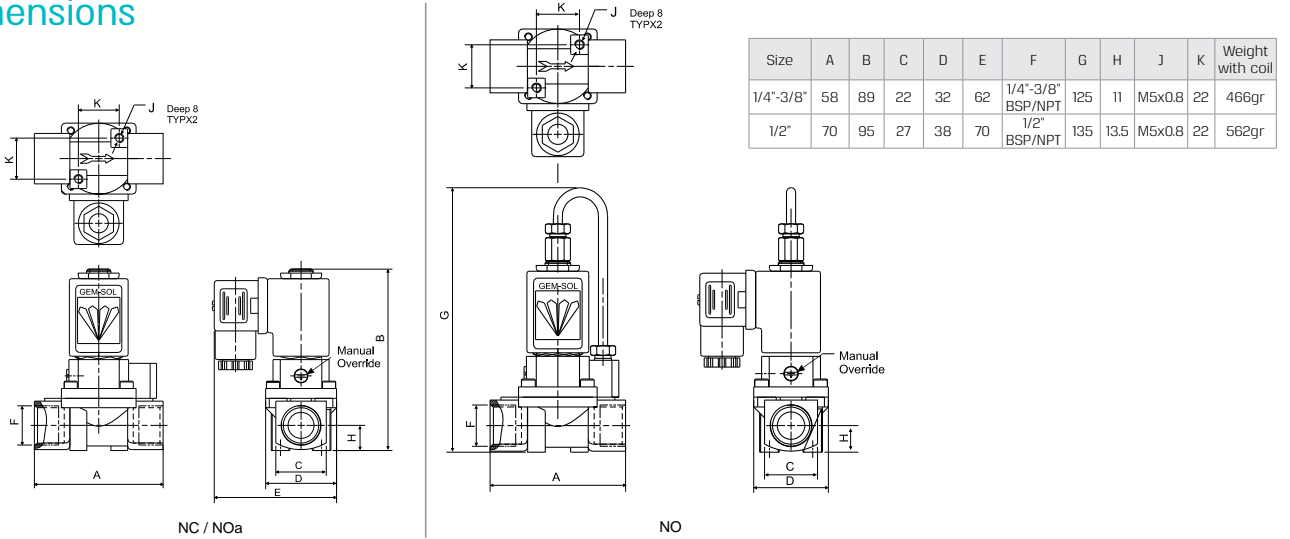

GEM-□r 16mm orifice
NC / NOa

How to Order

GEM-S	BODY	PORT	FUNCTION	SEALS	MANUAL OVERRIDE	VOLTAGE	POWER	CONNECTOR
	Brass 2	1/4" BSP 20	2W NC 1	NBR N	None 0	W/out coil 0	No coil 0	without 0
	Stainless Steel 3	1/4" NPT 21	2W NO ⁽¹⁾ 2	FKM V	Slot 2	6 1	AC8W 50Hz 1	with 1
		3/8" BSP 30	2W NO ⁽²⁾ w/out tube 2a	EPDM E	Knob 3	12 2	AC8W 60Hz 2	with LED 2
		3/8" NPT 31				24 3	DC10W 3	with bi-color LED 3
		1/2" BSP 40				48 4		flying leads coil 4
		1/2" NPT 41				110 5		with 1/2" Hub 5
		3/4" BSP 50				120 6		surge protection with LED 6
		3/4" NPT 51				220 7A		connector with moulded cable 7
		1" BSP 60				230 7		other 9
		1" NPT 61				240 8		
						Latch/other ⁽³⁾ 9		

Example: GEM-S-2202V2-321

GEM-SOL pilot operated, brass, 1/4"BSP, 2W NO, FKM seals, slot manual override, 24V AC8W 60Hz with connector

GEM-S	-	2	20	2	V	2	-	3	2	1
-------	---	---	----	---	---	---	---	---	---	---

(1) Option available in 1/4" - 1/2"

(2) Without manual override

(3) For specifying Latch type coil, please refer to GEM-A3P valve - How to Order table

* Note: When ordering without coil, please define what current and pressure rating is needed (DC, AC or ADC), otherwise an ADC valve will be supplied

How to Order

GEM-S	BODY	PORT	FUNCTION	SEALS	MANUAL OVERRIDE	VOLTAGE	POWER	CONNECTOR
	Brass 2	1/2" BSP 40r	2W NC 1	NBR N	None 0	W/out coil 0	No coil 0	without 0
		1/2" NPT 41r	2W NO 2	FKM V	Slot 2	6 1	AC8W 50Hz 1	with 1
		3/4" BSP 50r	2W NO ⁽¹⁾ w/out tube 2a	EPDM E	Knob 3	12 2	AC8W 60Hz 2	with LED 2
		3/4" NPT 51r				24 3	DC10W 3	with bi-color LED 3
						48 4		flying leads coil 4
						110 5		with 1/2" Hub 5
						120 6		surge protection with LED 6
						220 7A		connector with moulded cable 7
						230 7		other 9
						240 8		
						Latch/other ⁽²⁾ 9		

Example: GEM-S-240r1V2-321 (16mm orifice size)

GEM-SOL pilot operated, brass, 1/2"BSP, 2W NC, FKM seals, slot manual override, 24V AC8W 60Hz with connector

GEM-S	-	2	40r	1	V	2	-	3	2	1
-------	---	---	-----	---	---	---	---	---	---	---

(1) Without manual override.

(2) For specifying Latch type coil, please refer to GEM-A3P valve - How to Order table

* Note: When ordering without coil, please define what current and pressure rating is needed (DC, AC or ADC), otherwise an ADC valve will be supplied

* To order valves manufactured according to your specific requirements, please contact our technical sales department

ELECTRIC & HYDRAULIC VALVES

GEM-SOL | GEM-S

1/4", 1/2" 3 Way NC, NO

Technical Data

Function	3 Way NC, NO
Ports size	1/4", 1/2" BSP & NPT
Pressure range	See table
Kv (l/min)	See table
Temperature range	Fluid: -10°C to 80°C (no freezing) Ambient: -10°C to 50°C
Materials in contact with media	Manual override: NC: Push in lock hydraulic bypass NO: Brass screw or finger knob Main Valve: Brass Solenoid Operator: Stainless Steel AISI 300 & 400 series Seals: NBR, FKM, EPDM
Media	Air, water, light oil
Coil voltage	• Voltage and power consumption - see table • All Baccara coil voltages are ± 10% of nominal
Standard protection class	IP65 with connector * Option: IP68 (please refer to GEM-BP Coil)



Pressure (bar) & Flow

Size	Orifice (mm)	Pressure (bar)	Kv(l/min)
1/4"	8	0.8 to 12	18
1/2"	12		50

Voltage & Power Consumption

V	AC (W)						DC (W)		
	50 Hz			60 Hz			10	5.5	3.5
6							•		
12	•			•			•		
24	•			•			•		
48	•			•			•		
110	•			•			•		
120	•			•					
220	•						•		
230	•			•					
240	•			•			•		

- Available options

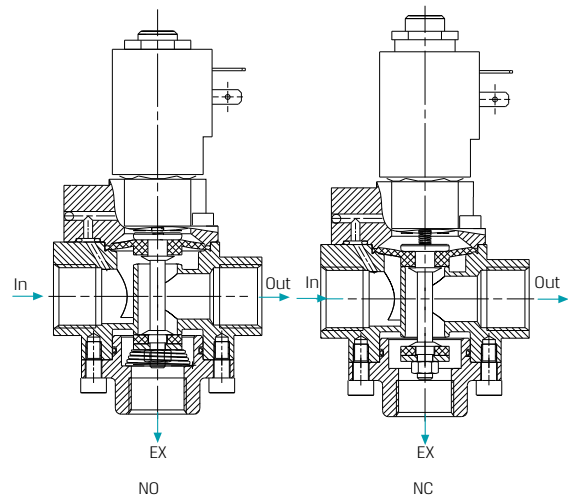

Dimensions

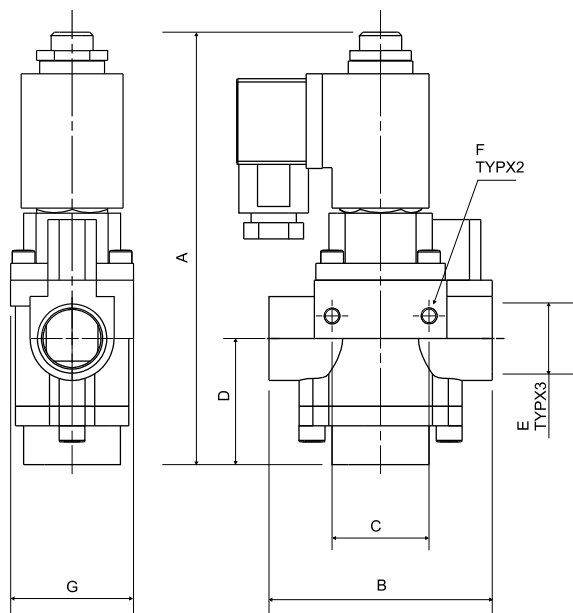

Size	A	B	C	D	E	F	G	Weight with coil
1/4"	124.5	58	25	32.5	1/4"	M4x0.7 Deep 6	32	540gr.
1/2"	134	69	30	32.5	1/2"	M5x0.8 Deep 7	38	758gr.

Optional Mounting Bracket

Size	H	I	J	K	L	M	N	O	P	Q
1/4"	15	25	Ø4.5	11	5	14	4	20	25	32
1/2"	20	30	Ø6	13	6	22	4	25	33	40

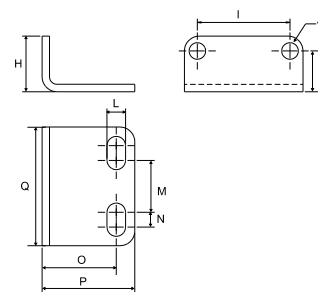

How to Order

GEM-S	BODY	PORT	FUNCTION	SEALS	MANUAL OVERRIDE	BRACKET	VOLTAGE	POWER	CONNECTOR
	Brass 2	1/4" BSP 20	3W NC 3	NBR N	None 0	without 0	W/out coil 0	No coil 0	without 0
		1/4" NPT 21	3W NO 4	FKM V	Slot ⁽¹⁾ 2	with 1	6 1	AC8W 50Hz 1	with 1
		1/2" BSP 40		EPDM E	Push lock ⁽²⁾ 5		12 2	AC8W 60Hz 2	with LED 2
		1/2" NPT 41					24 3	DC10W 3	with bi-color LED 3
							48 4		flying leads coil 4
							110 5		with 1/2" Hub 5
							120 6		surge protection with LED 6
							220 7A		connector with moulded cable 7
							230 7		other 9
							240 8		
							Latch/other ⁽³⁾ 9		

Example: GEM-S-2204V21-311

GEM-SOL pilot operated, brass, 1/4"BSP, NO, FKM, slot manual override with bracket, 24V AC 8W 50Hz with connector

GEM-S - 2 - 20 - 4 - V - 2 - 1 - 3 - 1 - 1

(1) For NO only

(2) For NC only

(3) For specifying Latch type coil, please refer to GEM-A3P valve - How to Order table

* Note: When ordering without coil, please define what current and pressure rating is needed (DC, AC or ADC), otherwise an ADC valve will be supplied

* To order valves manufactured according to your specific requirements, please contact our technical sales department

GEM-SOL | GEM-S

Pilot Operated 3/4" - 2" 2 Way NC, NO

Technical Data

Function	2 Way NC, NO
Ports size	3/4", 1", 1-1/2", 2" BSPT & NPT
Connection	Female BSPT or NPT thread
Pressure range	0.3 to 10 bar
Temperature range	Fluid: 5°C to 50°C (no freezing) Ambient: -10°C to 50°C
Solenoid	GEM-SOL 3/4" UNEF, 2 Way NC or NO solenoids. All voltages
Materials in contact with media	Manual override: Plastic (Reinforced Nylon) Body & cover: Plastic (Reinforced Nylon) Spring: Stainless Steel AISI 302 Diaphragm: NR Seals: NBR Screws: Stainless Steel AISI 304 Solenoid: Stainless Steel AISI 300 & 400 series
Coil voltage	• Voltage and power consumption - see table • All Baccara coil voltages are ± 10% of nominal
Standard protection class	IP65 with connector * Option: IP68 (please refer to GEM-BP Coil)

- Progressive opening and shut off that prevents water hammer



Head Loss for Fully Open Valve

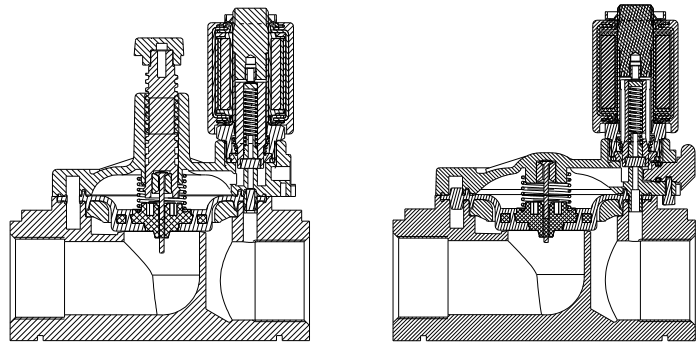
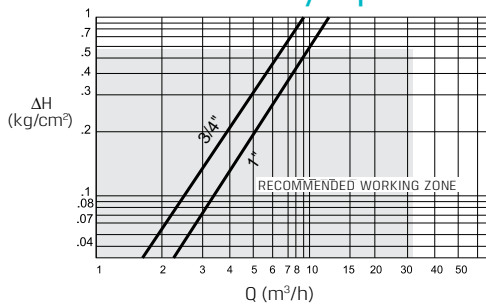

Flow direction →

Head Loss for Fully Open Valve

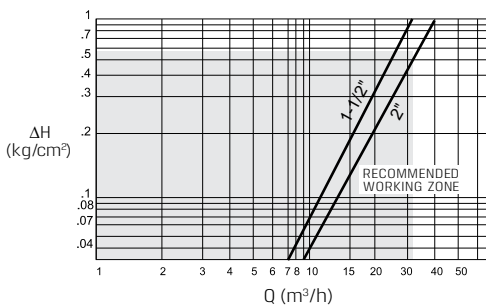

Flow Factor & Orifice

Size	Orifice (mm)	Kv (l/min)
3/4"	27	140
1"	27	200
1-1/2"	55	520
2"	55	600

Dimensions

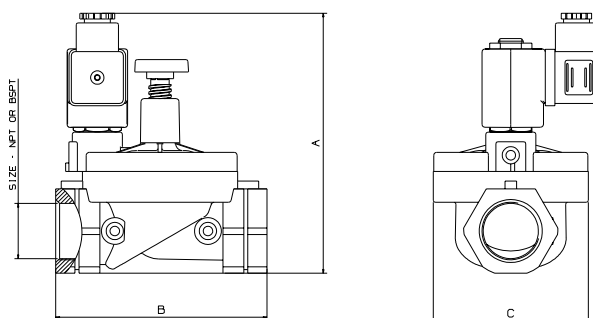

with flow control

Size	A	B	C
3/4"	108	110	81
1"	135.5	110	81
1-1/2"	180	160	126
2"	190	170	126

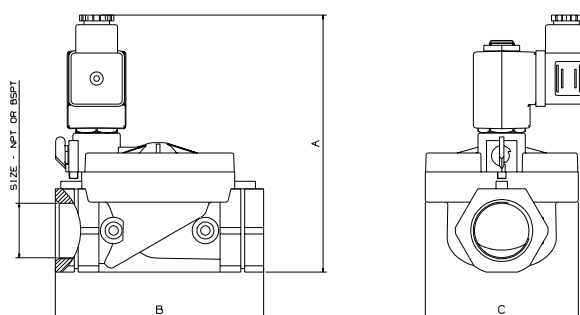

without flow control

Size	A	B	C
3/4"	128.5	110	81
1"	135.5	110	81
1-1/2"	168	160	126
2"	179.5	170	126

How to Order

* When ordering without coil, please define what current and pressure rating is needed (DC, AC)

GEM-S	BODY	PORT	FUNCTION	SEALS	MANUAL OVERRIDE	FLOW CONTROL	VOLTAGE	POWER	CONNECTOR							
Plastic	4	3/4" BSPT	50	2W NC 1	NR	N	None	0	with	1	W/out coil	0	No coil	0	without	0
		3/4" NPT	51	2WNO 2a			Plastic	1	without ⁽¹⁾	2	6	1	AC8W 50Hz	1	with	1
		1" BSPT	60								12	2	AC8W 60Hz	2	with LED	2
		1" NPT	61								24	3	DC10W	3	with bi-color LED	3
		1-1/2" BSPT	70								48	4	AC5.5W 50Hz	4	flying leads coil	4
		1-1/2" NPT	71								110	5	AC5.5W 60Hz	5	with 1/2" Hub	5
		2" BSPT	80								120	6			surge protection with LED	6
		2" NPT	81								220	7A			connector with moulded cable	7
										230	7			other	9	
										240	8					
										Latch/ other ⁽²⁾	9					

Example: GEM-S-450IN11-331

GEM-SOL pilot operated, nylon body, 3/4" BSPT, 2W NC, NR, plastic manual override, with flow control, 24V DC 10W with connector

GEM-S	-	4	50	1	N	1	1	-	3	3	1
-------	---	---	----	---	---	---	---	---	---	---	---

(1) 3/4", 1" valves only

(2) For specifying Latch type coil, please refer to GEM-A3P valve - How to Order table

* To order valves manufactured according to your specific requirements, please contact our technical sales department

GEM-SOL | GEM-S-4

Upstream Pilot Control Integrated with Gem-Sol Operator 3/4" - 2" 2 Way NC, NO

Technical Data

Function	2 Way NC, NO
Ports size	3/4", 1", 1-1/2", 2" BSPT & NPT
Connection	Female BSPT or NPT thread
Pressure range	0.3 to 10 bar
Temperature range	Fluid: 5°C to 50°C (no freezing) Ambient: -10°C to 50°C
Solenoid	GEM-SOL (GEM-OG)
Materials in contact with media	Manual override: Plastic (Reinforced Nylon) Body & cover: Plastic (Reinforced Nylon) Spring: Stainless Steel AISI 302 Diaphragm: NR Seals: NBR Screws: Stainless Steel AISI 304 Solenoid: Stainless Steel AISI 300 & 400 series
Coil voltage	• Voltage and power consumption - see table • All Baccara coil voltages are $\pm 10\%$ of nominal
Standard protection class	IP65 with connector * Option: IP68 (please refer to GEM-BP Coil)

- Progressive opening and shut off that prevents water hammer



Head Loss for Fully Open Valve

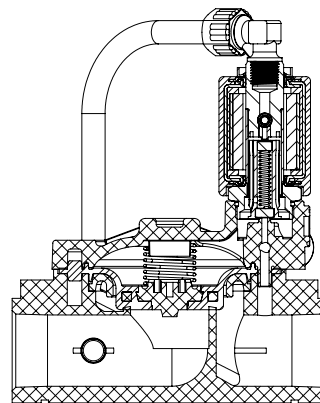
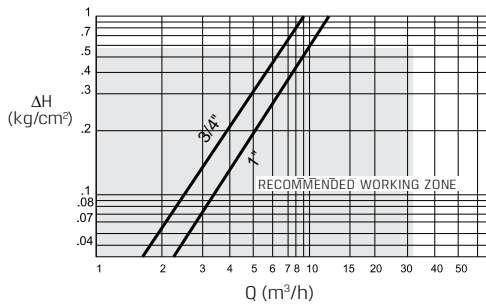

Flow direction →

Head Loss for Fully Open Valve

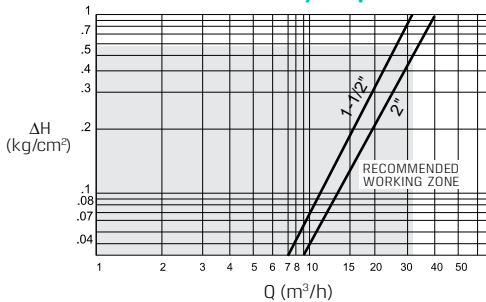

Flow Factor & Orifice

Size	Orifice (mm)	Kv (l/min)
3/4"	27	140
1"	27	200
1-1/2"	55	520
2"	55	600

Dimensions

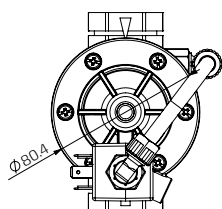
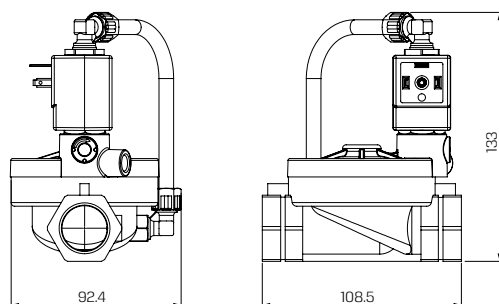

How to Order

* When ordering without coil, please define what current and pressure rating is needed (DC, AC)

GEM-S-4	-	BODY	PORT	FUNCTION	SEALS	MANUAL OVERRIDE	FLOW CONTROL	-	VOLTAGE	POWER	CONNECTOR					
Plastic	4	3/4" BSPT	50	2W NC 1	NR	N	None	0	with	1	W/out coil	0	No coil	0	without	0
			51	2WNO 2a			Plastic	1	without ⁽¹⁾	2	6	1	AC8W 50Hz	1	with	1
			60								12	2	AC8W 60Hz	2	with LED	2
			61								24	3	DC10W	3	with bi-color LED	3
			70								48	4	AC5.5W 50Hz	4	flying leads coil	4
			71								110	5	AC5.5W 60Hz	5	with 1/2" Hub	5
			80								120	6			surge protection with LED	6
			81								220	7A			connector with moulded cable	7
								230	7			other	9			
								240	8							
									Latch/ other ⁽²⁾	9						

Example: GEM-S-4-4501N11-331

GEM-SOL pilot operated upstream, nylon body, 3/4" BSPT, 2W NC, NR seals, plastic manual override, with flow control, 24V DC 10W with connector

GEM-S-4 - 4 50 1 N 1 1 - 3 3 1

(1) 3/4", 1" valves only

(2) For specifying Latch type coil, please refer to GEM-A3P valve - How to Order table

* To order valves manufactured according to your specific requirements, please contact our technical sales department

GEM-FLOW | G75-S

Pilot Operated 1/2" 2 Way NC

Technical Data

Function	2 Way NC
Ports size	1/2" BSP & NPT
Orifice size	12mm
Pressure range	0.5 to 12 bar * Minimum pressure differential of 0.5 is required
Kv (l/min)	35 l/min
Temperature range	Fluid: 5°C to 50°C (no freezing) Ambient: -10°C to 50°C
Materials in contact with media	Main Valve: Plastic (Reinforced Nylon) Solenoid Operator: Stainless Steel AISI 300 & 400 series Seals: NBR, EPDM, FKM Spring: Stainless Steel AISI 300 series
Solenoid	G75 2W NC solenoids, all voltages.
Coil voltage	• Voltage and power consumption - see table • All Baccara coil voltages are ± 10% of nominal
Standard protection class	IP65



Voltage & Power Consumption

	AC (W)	DC (W)
	50 Hz	
V	2	4.5
12	•	•
24	•	•
110	• 2 Way only	

- Available options

Voltage & Current

AC & DC

Solenoid	Voltage	Inrush [A]	Holding [A]
2 Way 50 Hz	V +10%	0.3	0.19
2 Way 60 Hz		0.2	0.14
3 Way 50/60 Hz		0.125	0.125
DC	n-20%	4.5W	

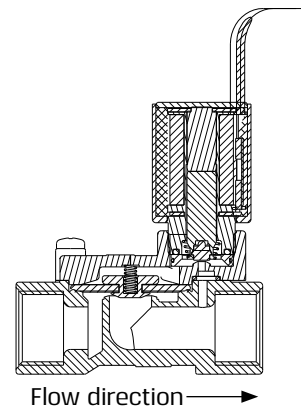

Latch Coil Resistance vs Input Voltage

Recommendations chart

Resistance [Ω]	Input voltage range [V]
4	6 - 9
9	12 - 14
12	14 - 16
23	18 - 21

Dimensions

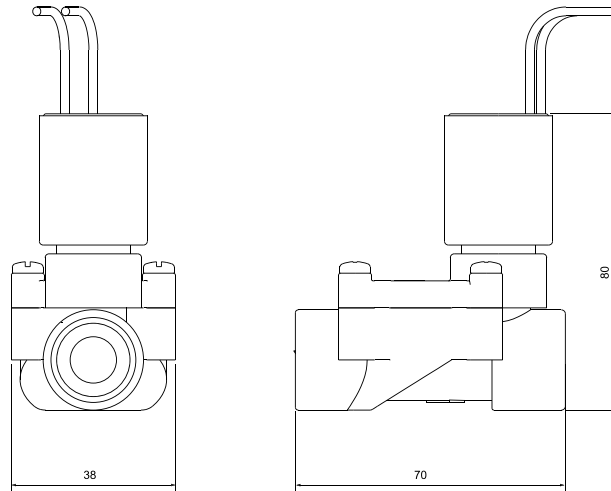

How to Order

G75-S	-	BODY	PORT	FUNCTION	SEALS	MANUAL OVERRIDE	-	VOLTAGE ⁽¹⁾	WIRES
		Plastic 4	1/2" BSP 40 1/2" NPT 41	2W NC 1	NBR N FKM V EPDM E	None 0		24V AC 1 12V AC 3 12V DC 4 24V DC 5 23Ω 6 110V AC 7 4Ω B 9Ω C 12Ω D	two null three ⁽²⁾ a

Example: G75-S-4401N0-1

G75 pilot operated, 1/2" BSP, 2W NC, NBR, no manual override, 24V AC, two wires

G75-S - 4 40 1 N 0 - 1

(1) For Latch: Refer to Latch Coil Resistance vs Input Voltage | Recommendations chart

(2) For Latch only

* To order valves manufactured according to your specific requirements, please contact our technical sales department

GEM-FLOW | G75-S

Electric 3/4" - 2" 2 Way NC

Technical Data

Function	2 Way NC
Ports size	3/4", 1", 1-1/2", 2" BSPT & NPT
Pressure range	0.3 to 10bar
Temperature range	(Fluid: 5°C to 50°C (no freezing) Ambient: -10°C to 50°C)
Materials in contact with media	Manual override: Plastic (Reinforced Nylon) Main Valve: Plastic (Reinforced Nylon) Solenoid Operator: Stainless Steel AISI 300 & 400 series Diaphragm: NR Seals: NBR Spring: Stainless Steel AISI 300 series
Solenoid	<ul style="list-style-type: none"> G75, 2W NC solenoids, all voltages. AC, DC and Latch
Coil voltage	<ul style="list-style-type: none"> Voltage and power consumption - see table All Baccara coil voltages are $\pm 10\%$ of nominal



G75-S | 1" | NC with plastic manual override



G75-S | 2" | NC Latch with handle manual override

Voltage & Current

AC & DC

Solenoid	Voltage	Inrush [A]	Holding [A]
2 Way 50 Hz	V +10% n-20%	0.3	0.19
2 Way 60 Hz		0.2	0.14
3 Way 50/60 Hz		0.125	0.125
DC		4.5W	

Voltage & Power Consumption

V	AC (W)	DC (W)
	50 Hz	
12	•	•
24	•	•
110	•	•
	2 Way only	

- Available options

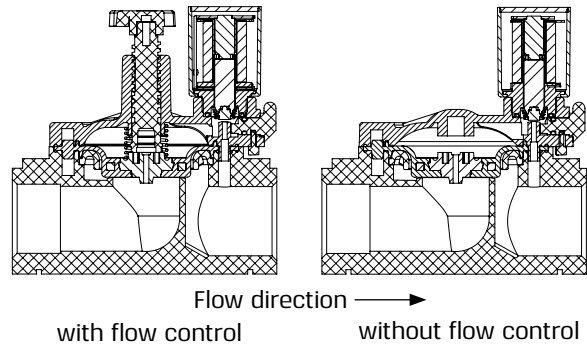

Head Loss for Fully Open Valve

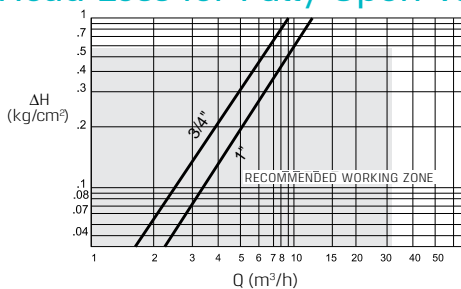

Head Loss for Fully Open Valve

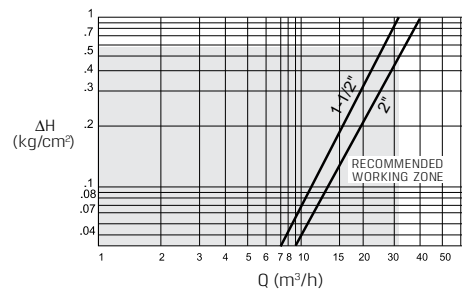

Latch Coil Resistance vs Input Voltage

Recommendations chart

Resistance [Ω]	Input voltage range [V]
4	6 - 9
9	12 - 14
12	14 - 16
23	18 - 21

Dimensions

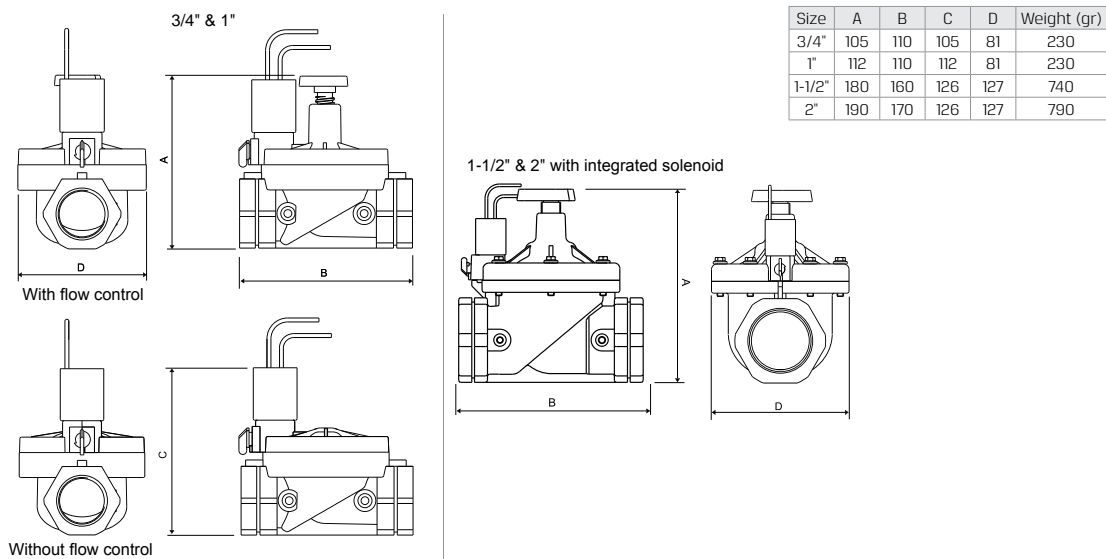

How to Order

G75-S	-	PORT	FUNCTION	MANUAL OVERRIDE	FLOW CONTROL	VOLTAGE ⁽³⁾	WIRES
		3/4" BSPT 50	2W NC 1	None 0	with 5	24V AC 1	two null
		3/4" NPT 51		Plastic 1	without ⁽²⁾ 6	12V AC 3	three ⁽¹⁾ a
		1" BSPT 60		Handle ⁽¹⁾ 2		12V DC 4	
		1" NPT 61				24V DC 5	
		1-1/2" BSPT 70				23Ω 6	
		1-1/2" NPT 71				110V AC 7	
		2" BSPT 80				4Ω B	
		2" NPT 81				9Ω C	
						12Ω D	

Example: G75-S-501051

G75 electric valve, 3/4" BSPT, 2W NC, no manual override, with flow control, 24V AC, two wires

G75-S - 50 1 0 5 1

(1) For Latch only

(2) 3/4", 1" valves only

(3) For Latch: Refer to Latch Coil Resistance vs Input Voltage | Recommendations chart

* To order valves manufactured according to your specific requirements, please contact our technical sales department

GEM-SOL | GEM-Z

Zero Differential Pressure 1/4" - 3/4" 2 Way NC, NO

Technical Data

Function	2 Way NC, NO
Ports size	1/4", 1/2", 3/4" BSP & NPT
Pressure range	See table * For plastic body, maximum working pressure is 4 bar
Kv (l/min)	See table
Temperature range	Fluid: -10°C to 80°C (no freezing) Ambient: -10°C to 50°C
Materials in contact with media	Main Valve: Brass, Stainless Steel AISI 316, Plastic (Reinforced Nylon)* * Plastic (Reinforced Nylon): only available in 1/2" Solenoid Operator: Stainless Steel AISI 300 & 400 series Seals: NBR, FKM, EPDM
Media	Air, water, oil
Coil voltage	• Voltage and power consumption - see table • All Baccara coil voltages are ± 10% of nominal
Standard protection class	IP65 with connector * Option: IP68 (please refer to GEM-BP Coil)

- When switching from an AC to a DC coil, the solenoid operator must be changed as well.
- Can be used in vacuum application from -1 bar to maximum pressure - see tables.



Brass | 1/2" | NC

Plastic | 1/2" | NC



Stainless Steel | 1/2" | NC

Pressure (bar) & Flow NC (GEM-Z)

Size	Orifice (mm)	Pressure (bar)		Kv (l/min)
		AC	DC	
1/4"	8	0 to 14	0 to 7	12
1/2"	12	0 to 14	0 to 8	18

Pressure (bar) & Flow NC (GEM-Z-□□r)

Size	Orifice (mm)	Pressure (bar)		Kv (l/min)
		AC	DC	
1/2"	16	0 to 10	0 to 6	60
3/4"	16	0 to 10	0 to 6	80

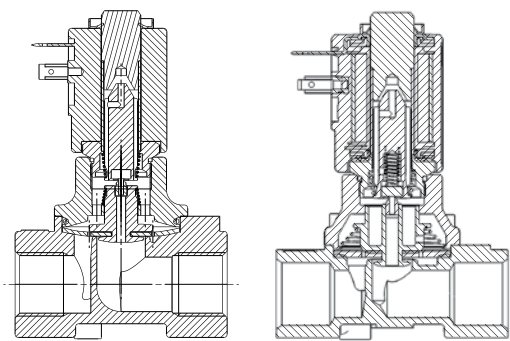

GEM-Z□r

→ Flow direction

Pressure (bar) & Flow NO (GEM-Z)

Size	Orifice (mm)	Pressure (bar)		Kv (l/min)
		AC	DC	
1/4"	8	0 to 8	0 to 8	12
1/2"	12	0 to 8	0 to 8	20

Voltage & Power Consumption

V	AC (W)						DC (W)		
	50 Hz			60 Hz					
	8	5.5	2.5	8	5.5	2.5	10	5.5	3.5
6							•		
12	•			•			•		
24	•			•			•		
48	•			•			•		
110	•			•			•		
120	•			•					
220	•			•			•		
230	•			•	•				
240	•			•			•		

- Available options

Dimensions

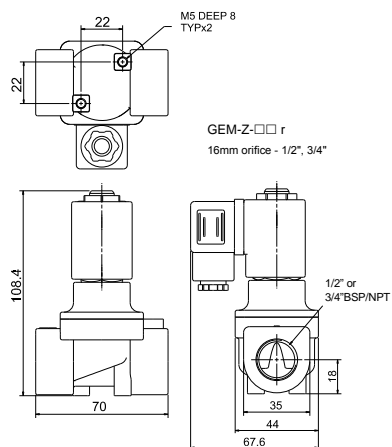
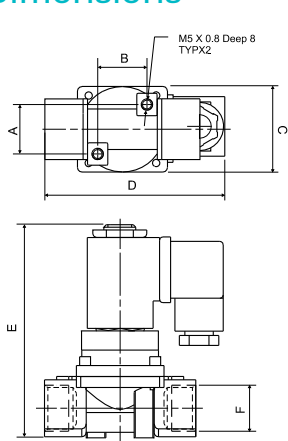

Size	A	B	C	D	E	F	Weight with coil
1/4"	22	22	32	58	89	1/4" BSP/NPT	415gr.
1/2"	22	22	38	70	95	1/2" BSP/NPT	530gr.

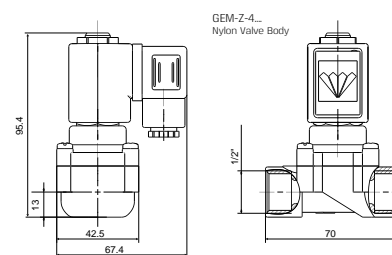

How to Order

* When ordering without coil, please define what current and pressure rating is needed (DC, AC)

GEM-Z	-	BODY	PORT	FUNCTION	SEALS	-	VOLTAGE	POWER	CONNECTOR				
Brass	2	1/4" BSP	20	2W NC	1	NBR	N	W/out coil	0	No coil	0	without	0
Stainless Steel ⁽¹⁾	3	1/4" NPT	21	2W NO ⁽⁴⁾	2a	FKM	V	6	1	AC8W 50Hz	1	with	1
Plastic ⁽²⁾	4	1/2" BSP	40			EPDM	E	12	2	AC8W 60Hz	2	with LED	2
			24					3	DC10W	3	with bi-color LED	3	
		48	4							flying leads coil	4		
		110	5							with 1/2" Hub	5		
		120	6							surge protection with LED	6		
		220	7A							connector with moulded cable	7		
230	7			other	9								
240	8												
Latch/ other ⁽⁵⁾	9												

Example: GEM-Z-2401N-221

GEM-SOL zero differential, brass, 1/2" BSP, 2W NC, NBR, 12V AC8W 60Hz with connector

GEM-Z - 2 - 40 - 1 - N - 2 - 2 - 1

(1) Not available for GEM-Z-□□r

(2) Only available in 1/2"

(3) 16mm orifice

(4) NO function without M/O, not available for GEM-Z-□□r

(5) For specifying Latch type coil, please refer to GEM-A3P valve - How to Order table

* To order valves manufactured according to your specific requirements, please contact our technical sales department

GEM-FLOW | G75-S

Hydraulic 3/4"- 2" 2 Way

Technical Data

Function	2 Way
Ports size	3/4", 1", 1-1/2", 2" BSPT & NPT
Pressure range	0.3 to 10bar
Temperature range	Fluid: 5°C to 50°C (no freezing)
Materials in contact with media	Main Valve: Plastic (Reinforced Nylon) Diaphragm: NR Seals: Buna - N Spring: Stainless Steel AISI 300 series



No inline pilot port | with flow control



Upstream inline pilot port | with flow control

Head Loss for Fully Open Valve

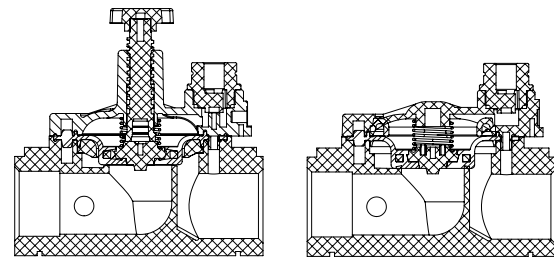
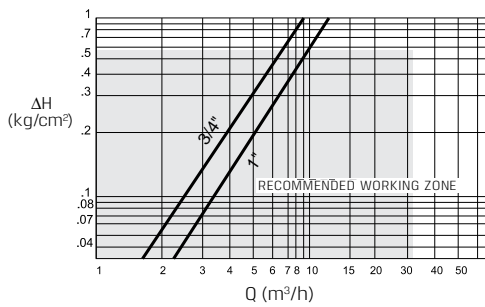

Flow direction →
with flow control without flow control

Head Loss for Fully Open Valve

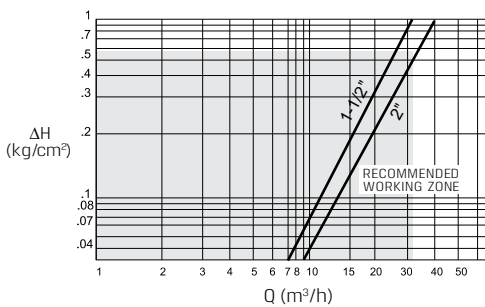

Dimensions

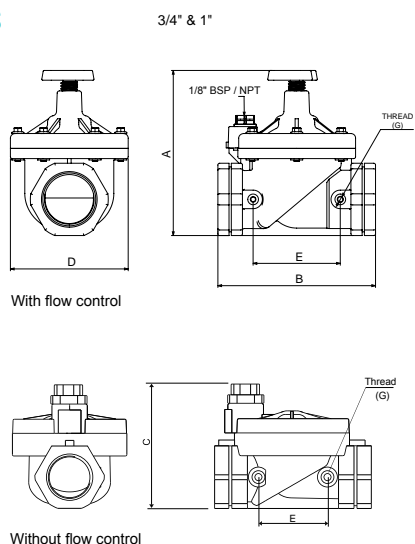

Size	A	B	C	D	E	ØG	Weight (gr.)
3/4"	105	110	77	81	52.5	1/8"NPT/BSP	230
1"	112	110	84	81	48.5	1/8"NPT/BSP	230
1-1/2"	180	160	98	127	92	1/4"NPT/BSP	740
2"	190	170	98	127	94	1/4"NPT/BSP	790

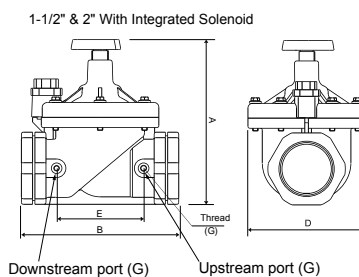

How to Order

G75-S	-	PORT	FUNCTION INLINE PILOT PORTS		FLOW CONTROL		
		3/4" BSPT	50	none	0	with	5
		3/4" NPT	51	upstream only	1	without ⁽¹⁾	6
		1" BSPT	60	downstream only	2		
		1" NPT	61	both	3		
		1-1/2" BSPT	70				
		1-1/2" NPT	71				
		2" BSPT	80				
		2" NPT	81				

Example: G75-S-5015

G75 hydraulic valve, 3/4" BSPT, 1/8" upstream inline pilot port, with flow control

G75-S - 50 - 1 - 5

(1) 3/4", 1" valves only

* To order valves manufactured according to your specific requirements, please contact our technical sales department

GEM-FLOW | G75-S

3 Way Integral Solenoid Pilot Control 3/4" - 2" NC

Technical Data

Solenoid	Supplied with 3 Way NO 1.2mm G75 operator
Assembly	Upstream pilot control valve is supplied with finger filter and accessories

- For technical information, refer to G75-S | Electric 3/4" - 2" 2 Way NC

Voltage & Power Consumption

V	AC (W)	DC(W)
	50 Hz	
12	•	•
24	•	•

- Available options

Voltage & Current

Solenoid	Voltage	Inrush [A]	Holding [A]
2 Way 50 Hz	V +10% n-20%	0.3	0.19
2 Way 60 Hz		0.2	0.14
3 Way 50/60 Hz *		0.125	0.125
DC		4.5W	

- * Except 24V AC without Diode

Latch Coil Resistance vs Input Voltage

Recommendations chart

Resistance [Ω]	Input voltage range [V]
4	6 - 9
9	12 - 14
12	14 - 16
23	18 - 21

How to Order

G75-S -	PORT	FUNCTION	MANUAL OVERRIDE	FLOW CONTROL	VOLTAGE (3)	WIRES
	3/4" BSPT 50	External pilot	4 None	0 with	5 24V AC	1 two null
	3/4" NPT 51	Upstream pilot	4H Plastic	1 without(1)	6 24V AC w/out Diode	1R three(2) a
	1" BSPT 60		Handle(2)	2	12 V AC	3
	1" NPT 61				12 V DC	4
	1-1/2" BSPT 70				24V DC	5
	1-1/2" NPT 71				23Ω	6
	2" BSPT 80				4Ω	B
	2" NPT 81				9Ω	C
					12Ω	D

Example: G75-S-704151

G75 1-1/2" BSPT, external pilot, plastic manual override, with flow control, 24V AC, two wires

G75-S	-	70	4	1	5	1
-------	---	----	---	---	---	---

- (1) For 3/4", 1" valves only
- (2) For Latch only
- (3) For Latch: Refer to Latch Coil Resistance vs Input Voltage | Recommendations chart



Upstream pilot control

External pilot control

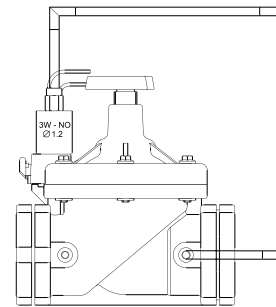

Upstream pilot control

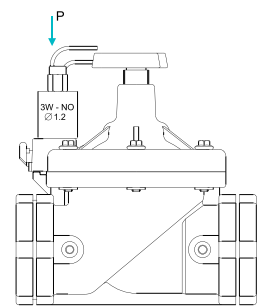

External pilot control

* To order valves manufactured according to your specific requirements, please contact our technical sales department

GEM-FLOW | G75-SE

3 Way External Solenoid Pilot Control 3/4" - 2" NC, NO

Technical Data

Solenoid	Supplied with 3 Way 12mm G75 solenoid or G75-A3P 2.6 mm latch
Assembly	Supplied with finger filter and accessories

- For technical information, refer to G75-S | Electric 3/4" - 2" 2 Way NC

Voltage & Power Consumption

	AC (W) 50 Hz	DC(W)
V	2	4.5
12	•	•
24	•	•

- Available options

Voltage & Current

AC & DC

Solenoid	Voltage	Inrush [A]	Holding [A]
2 Way 50 Hz	V +10% n-20%	0.3	0.19
2 Way 60 Hz		0.2	0.14
3 Way 50/60 Hz *		0.125	0.125
DC		4.5W	

- * Except 24V AC without Diode



NC valve

NO valve

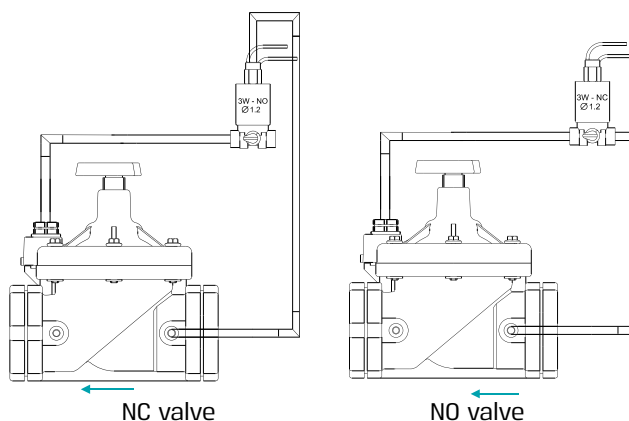

NC valve

NO valve

How to Order

G75-SE -	PORT	FUNCTION ⁽³⁾	MANUAL OVERRIDE	FLOW CONTROL	VOLTAGE ⁽⁴⁾	WIRES
	3/4" BSPT 50	2W NC 1	None 0	with 5	24V AC	1 two null
	3/4" NPT 51	2W NO 2	Plastic 1	without ⁽¹⁾ 6	24V AC w/out Diode	1R three ⁽²⁾ a
	1" BSPT 60				12 V AC	3
	1" NPT 61				12 V DC	4
	1-1/2" BSPT 70				24V DC	5
	1-1/2" NPT 71				23Ω	6
	2" BSPT 80				4Ω	B
	2" NPT 81				9Ω	C
					12Ω	D
					1Ω ⁽⁵⁾	PA
					4Ω ⁽⁵⁾	PB
					9Ω ⁽⁵⁾	PC

Example: G75-SE-702151

G75 1-1/2" BSPT, 2W NO, plastic manual override, with flow control, 24V AC, two wires

G75-SE - 70 2 1 5 1

- (1) For 3/4", 1" valves only
- (2) For Latch only
- (3) Refers to the valve:
3 Way NC solenoid = NO valve
3 Way NO solenoid = NC valve
- (4) For Latch: Refer to Latch Coil Resistance vs Input Voltage | Recommendations chart
- (5) For G75-A3P Latch

- * To order valves manufactured according to your specific requirements, please contact our technical sales department

Latch Coil Resistance vs Input Voltage

Recommendations chart

G75-A Latch	
Resistance [Ω]	Input voltage range [V]
4	6 - 9
9	12 - 14
12	14 - 16
23	18 - 21
G75-A3P Latch	
Resistance [Ω]	Input voltage range [V]
1	8 - 12
4	12 - 18
9	18 - 24

GEM-FLOW | G75

3 Way Manual Selector 3/4" - 2" NC, NO

Technical Data

Solenoid	Supplied with 3 Way 1.2mm G75 solenoid or G75-A3P 2.6 mm latch
Assembly	Supplied with finger filter and accessories
Manual override	Manual override with 3 positions: <ul style="list-style-type: none"> • AUTO - for automatic operation (valve is open when solenoid is energized) • MANUAL - valve is kept open • CLOSE - valve is kept closed
Pressure	A minimum pressure differential of 1 bar is required

• For technical information, refer to G75-S | Electric 3/4" - 2" 2 Way NC



3 Way Manual selector

With solenoid

Voltage & Power Consumption

	AC (W)	
	50 Hz	DC(W)
V	2	4.5
12	•	•
24	•	•

• Available options

Voltage & Current

AC & DC

Solenoid	Voltage	Inrush [A]	Holding [A]
2 Way 50 Hz	V +10% n-20%	0.3	0.19
2 Way 60 Hz		0.2	0.14
3 Way 50/60 Hz *		0.125	0.125
DC		4.5W	

* Except 24V AC without Diode

Latch Coil Resistance vs Input Voltage

Recommendations chart

G75-A Latch	
Resistance [Ω]	Input voltage range [V]
4	6 - 9
9	12 - 14
12	14 - 16
23	18 - 21

G75-A3P Latch	
Resistance [Ω]	Input voltage range [V]
1	8 - 12
4	12 - 18
9	18 - 24

Latch Coil Resistance vs Input Voltage

Recommendations chart

G75-A Latch	
Resistance [Ω]	Input voltage range [V]
4	6 - 9
9	12 - 14
12	14 - 16
23	18 - 21

G75-A3P Latch	
Resistance [Ω]	Input voltage range [V]
1	8 - 12
4	12 - 18
9	18 - 24

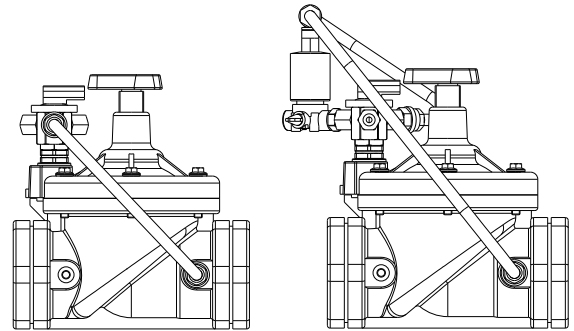

3 Way Manual selector

Manual selector with external 3 Way NO solenoid

How to Order

G75	-	TYPE	-	PORT	FUNCTION ⁽¹⁾	FLOW CONTROL	VOLTAGE ⁽⁴⁾	WIRES	
		Hydraulic with Manual Selector	SM	3/4" BSPT	50	2W NC 1	with 5	No solenoid (hydraulic) 0	two null
		Electric	EL	3/4" NPT	51	2W NO 2	without ⁽²⁾ 6	24V AC 1	three ⁽³⁾ a
		Electric with Manual Selector	ELM	1" BSPT	60			24V AC w/out Diode 1R	
				1" NPT	61			12V AC 3	
				1-1/2" BSPT	70			12V DC 4	
				1-1/2" NPT	71			24V DC 5	
				2" BSPT	80			23Ω 6	
				2" NPT	81			4Ω B	
								9Ω C	
								12Ω D	
								1Ω ⁽⁵⁾ PA	
								4Ω ⁽⁵⁾ PB	
								9Ω ⁽⁵⁾ PC	

Example: G75-ELM-70151

G75 3 Way electric with manual selector, 1-1/2" BSPT, 2W NC with flow control, 24V AC, two wires

G75 - ELM - 70 1 5 1

- (1) Refers to the valve:
3 Way NC solenoid = NO valve
3 Way NO solenoid = NC valve
- (2) For 3/4", 1" valves only
- (3) For Latch only
- (4) For Latch: Refer to Latch Coil Resistance vs Input Voltage | Recommendations chart
- (5) For G75-A3P Latch

* To order valves manufactured according to your specific requirements, please contact our technical sales department

GEM-FLOW | G75

Pressure Reducing 3/4" - 2" 2 Way NC

Technical Data

Solenoid	Supplied with 3 Way NO 12mm G75 solenoid or G75-A3P 2.6 mm latch
Assembly	Supplied with finger filter
Pressure	<ul style="list-style-type: none"> Pilot pressure must be equal to, or higher than line pressure A minimum pressure differential of 1 bar is required

• For technical information, refer to G75-S | Electric 3/4" - 2" 2 Way NC

Voltage & Power Consumption

V	AC (W) 50 Hz	DC(W)
24	2	4.5
12	•	•
24	•	•

• Available options

Voltage & Current

AC & DC

Solenoid	Voltage	Inrush [A]	Holding [A]
2 Way 50 Hz	+10%	0.3	0.19
2 Way 60 Hz		0.2	0.14
3 Way 50/60 Hz *	n-20%	0.125	0.125
DC		4.5W	

* Except 24V AC without Diode

Latch Coil Resistance vs Input Voltage

Recommendations chart

G75-A Latch	
Resistance [Ω]	Input voltage range [V]
4	6 - 9
9	12 - 14
12	14 - 16
23	18 - 21
G75-A3P Latch	
Resistance [Ω]	Input voltage range [V]
1	8 - 12
4	12 - 18
9	18 - 24

How to Order

G75	-	TYPE	-	PORT	FUNCTION	FLOW CONTROL	VOLTAGE ⁽³⁾	WIRES	PRESSURE RANGE
		Pressure Reducing	PR	3/4" BSPT 50	2W NC 1	with 5	No solenoid (hydraulic) 0	two null	0.5-5 bar Y
		With Manual Selector	PRM	3/4" NPT 51		without ⁽¹⁾ 6	24V AC 1	three ⁽²⁾ a	1-10 bar G
		Electric Without Manual Selector	PREL	1" BSPT 60			24V AC w/out Diode 1R		
		Electric With Manual Selector	PRELM	1" NPT 61			12V AC 3		
				1-1/2" BSPT 70			12V DC 4		
				1-1/2" NPT 71			24V DC 5		
				2" BSPT 80			23Ω 6		
				2" NPT 81			4Ω B		
							9Ω C		
							12Ω D		
							1Ω ⁽⁴⁾ PA		
							4Ω ⁽⁴⁾ PB		
							9Ω ⁽⁴⁾ PC		

Example: G75-PR-70151Y

G75 pressure reducing valve, 1-1/2" BSPT, 2W NC with flow control, 24V AC, two wires, 0.5-5 bar

G75 - PR - 70 1 5 1 Y

- (1) For 3/4", 1" valves only
- (2) For Latch only
- (3) For Latch: Refer to Latch Coil Resistance vs Input Voltage | Recommendations chart
- (4) For G75-A3P Latch



Pressure reducing | 0.5-5 bar / 1-10 bar

Pressure Reducing | PR

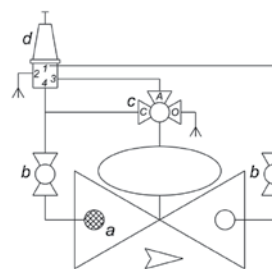

* To order valves manufactured according to your specific requirements, please contact our technical sales department

GEM-FLOW | G75-Z

Electric Zero Differential Pressure 3/4" - 2" 2 Way NC

Technical Data

Function	2 Way NC
Ports size	3/4", 1", 1-1/2", 2" BSPT & NPT
Pressure range	Line: 0-6 bar Pilot: 1.5 bar above line pressure
Temperature range	Fluid: 5°C to 50°C (no freezing)
Materials in contact with media	Manual override: Plastic (Reinforced Nylon) Main Valve: Plastic (Reinforced Nylon) Solenoid Operator: Stainless Steel AISI 300 & 400 series Diaphragm: NR Seals: Buna-N Spring: Stainless Steel AISI 300 series
Solenoid	Supplied with G75 1.2mm 3 Way NO solenoid

- For overall dimensions, refer to G75-S | Electric 3/4" - 2" 2 Way NC



Voltage & Power Consumption

	AC (W)	DC(W)
	50 Hz	
V	2	4.5
12	•	•
24	•	•

- Available options

Voltage & Current

AC & DC

Solenoid	Voltage	Inrush [A]	Holding [A]
2 Way 50 Hz	V +10% n-20%	0.3	0.19
2 Way 60 Hz		0.2	0.14
3 Way 50/60 Hz *		0.125	0.125
DC		4.5W	

- * Except 24V AC without Diode

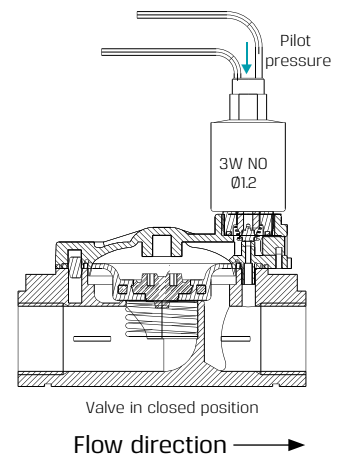

Latch Coil Resistance vs Input Voltage

Recommendations chart

Resistance [Ω]	Input voltage range [V]
4	6 - 9
9	12 - 14
12	14 - 16
23	18 - 21

How to Order

G75-Z	PORT	FUNCTION	MANUAL OVERRIDE	FLOW CONTROL	VOLTAGE ⁽³⁾	WIRES
	3/4" BSPT 50	2W NC 1	None 0	with 5	without 0	two null
	3/4" NPT 51		Plastic 1	without ⁽¹⁾ 6	24V AC 1	three ⁽²⁾ a
	1" BSPT 60	Handle ⁽²⁾ 2			24V AC w/out Diode 1R	
	1" NPT 61				12V AC 3	
	1-1/2" BSPT 70				12V DC 4	
	1-1/2" NPT 71				24V DC 5	
	2" BSPT 80				23Ω 6	
	2" NPT 81				110V AC 7	
					4Ω B	
		9Ω C				
					12Ω D	

Example: G75-Z-601151

G75 electric valve, 1" BSPT, 2WNC, plastic manual override with flow control, 24V AC, two wires

G75-Z - 60 1 1 5 1

(1) 3/4", 1" valves only

(2) For latch only

(3) For Latch: Refer to Latch Coil Resistance vs Input Voltage | Recommendations chart

* To order valves manufactured according to your specific requirements, please contact our technical sales department

b **BACCARA**[®]
AUTOMATION & CONTROL



ELECTRIC & HYDRAULIC

VALVES | G500

GEM-FLOW 500 Series	Hydraulic Control Valves	68
GEM-FLOW	Operating Principals	69
GEM-FLOW	Available Models	70
GEM-FLOW	Hydraulic Performance	71
GEM-FLOW G500	4" Hydraulic Valves	72
GEM-FLOW G500	4" Hydraulic Valves	73
GEM-FLOW G500-S	Hydraulic with Manual Selector 1-1/2" - 4"	74
GEM-FLOW G500-EL	Electric Solenoid Control Valve 1-1/2" - 4"	75
GEM-FLOW G500-C	DC Battery Controller 1-1/2" - 4"	76
GEM-FLOW G500-PR	Pressure Reducing 1-1/2" - 4"	77
GEM-FLOW G500-PREL	Solenoid Controlled Pressure Reducing 1-1/2" - 4"	78
GEM-FLOW G500-PRPS	Pressure Reducing & Sustaining Control Valve 1-1/2" - 4"	79
GEM-FLOW G500-QR	Quick Pressure Relief 1-1/2" - 4"	80
GEM-FLOW G500-PS	Pressure Sustaining Control Valve 1-1/2" - 4"	81



GEM-FLOW | 500 Series

Hydraulic Control Valves

General Description

500 series valves are direct diaphragm closing automatic hydraulic control valves which work with line pressure. They ensure easy and smooth flow with minimum pressure losses thanks to excellent design of the valve body and diaphragm. No wearable parts such as stem, bearing and seat exist in the main valve body and valve life is much longer than other competitor valves. The only movable part of the valve is the valve diaphragm.

500 series hydraulic control valves are designed so that they can be used in portable water force network, agricultural irrigation, filtration and industrial applications by even unskilled personnel.

General Features

- Easy use and maintenance due to simple design
- Low cost
- Operation in wide pressure range
- Perfect modulation even in lower flow rates
- Anti-surge closing and opening with flexible diaphragm
- Full tightness thanks to reinforced diaphragm and inner spring
- Long life with Glass Reinforced Polyamide material
- Wide control application range by using different pilot valves
- Operation in both horizontal and vertical positions in application areas



GEM-FLOW

Operating Principals

It is an automatic hydraulic control valve designed to make desired modulation in main valve network line as full hydraulically by means of line pressure without requiring different energy sources such as electric, pneumatic or mechanical energy.

Valve Opening Mode

When the pilot valve located on the main valve being in closed position, is brought into relief position, pressurized water within control chamber on main valve diaphragm is released. When line pressure (P1) reaches to a value which will overcome spring force, water carries valve to fully open position by applying a hydraulic force to valve diaphragm from bottom.

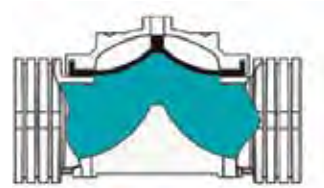

Modulation Mode

Pilot valves which are connected to main valve actuator ensure that main valve works in modulated mode. According to flow rate or pressure conditions, it ensures that main valve works in modulation mode by controlling pressure of fluid within main valve actuator (control chamber).

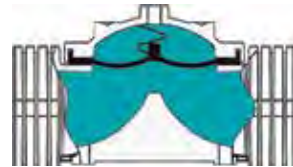

Valve Closing Mode

Pilot valves which are connected to main valve actuator ensure that main valve works in modulated mode. According to flow rate or pressure conditions, it ensures that main valve works in modulation mode by controlling pressure of fluid within main valve actuator (control chamber).

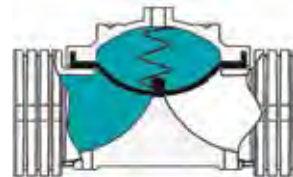

GEM-FLOW

Available Models

Technical Data

Pressure range	Standard	0.7 - 10 bar (10 - 160 psi)
Temperature range	Fluid Ambient	(-10°C to 60°C (no freezing) -10°C to 60°C
Connection	Threaded	BSPT-NPT
Hydraulic connections	Standard	Reinforced Nylon (Air Brake) Hydraulic Pipe- SAE J 844
Actuator type	Standard	Diaphragm Closing Type with Single Control Chamber and Diaphragm Actuator

Available Models

MODEL	G500	
Connection	Threaded	
Material	Glass reinforced polyamide	
Body	Globe	
Maximum working pressure	10 bar	160psi
Available sizes	inch	mm
	1-1/2"	40
	2"	50
	2-1/2"	65
	3"	80

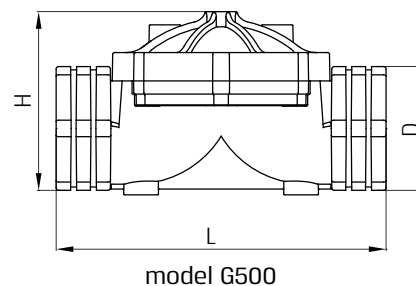

Dimensions

DN		D		L		H	
inch	mm	inch	mm	inch	mm	inch	mm
1-1/2"	40	2-1/2"	62	7-7/8"	200	4-3/8"	110
2"	50	3"	75	7-7/8"	200	4-3/8"	110
2-1/2"	65	3-3/4"	95	9-7/8"	250	5-3/8"	138
3"	80	4-1/4"	109	9-7/8"	250	5-3/8"	145

Order Information

Please submit following information to our sales department when ordering:

- Maximum flow rate.....m3/h
- Maximum network/line pressure..... bar
- Main line size..... mm
- Valve connection type
- Maximum upstream pressure..... bar
- Minimum upstream pressure..... bar
- Desired downstream pressure..... bar
- Electric voltage value to be used..... volt

GEM-FLOW

Hydraulic Performance

Hydraulic Performance Chart

VALVE SIZE	mm	40	50	65	80
	inch	1-1/2"	2"	2-1/2"	3"
Kv	m ³ /h @ 1 bar	60	70	80	90
Cv	gpm @ 1 psi	70	85	95	105

- Kv: Valve Flow Coefficient (fluid passing under 1 bar pressure difference in m³/h @ 1 bar)
- Cv: Valve Flow Coefficient (fluid passing under 1 bar pressure difference in gpm @ 1 bar)
- Q: Flow Rate (m³/h)
- ΔP: Head Loss (bar)
- G: Specific weight of water (1.0 for water)

$$Kv, (Cv) = Q \sqrt{\frac{G}{\Delta P}}$$

$$Cv = 1,155 Kv$$

Head Loss Chart

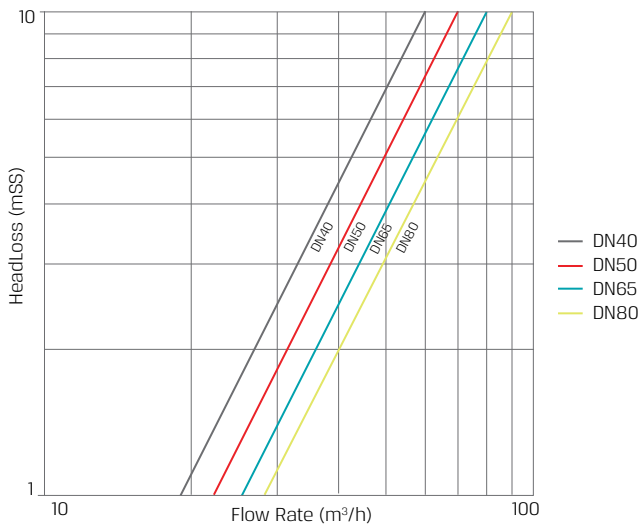

Main Parts

NO.	PART NAME	MATERIAL
1	Body	Glass reinforced polyamide
2	Bonnet	Glass reinforced polyamide
3	Diaphragm	Natural Rubber
4	Spring thrust ring	Glass reinforced polyamide
5	Spring	SST302
6	Bolt	SST304
7	Nut	Brass

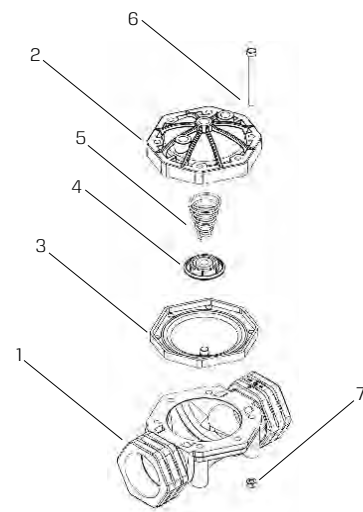

GEM-FLOW | G500

4" Hydraulic Valves

Typical Applications

- Agricultural irrigation
- Landscaping applications
- Greenhouse applications
- Mining process
- Industrial process

Technical Data

General Specifications	
Pressure range	0.7-10 bar / 9-145 Psi
Temperature range	-10°C to 80°C (no freezing)
Valve size	4" (100 mm)
Material Properties	
Body Cover	PA GFR
Diaphragm	NR
Spring thrust ring	PA GFR
Spring	Stainless Steel AISI 302
Bolts	Stainless Steel A2
Flange, Flange adaptor	PA GFR
Threaded adaptor	PA GFR
O-rings	NBR
Connection	
Flanged	ISO, ANSI
Threaded	BSP, NPT



Head Loss Chart

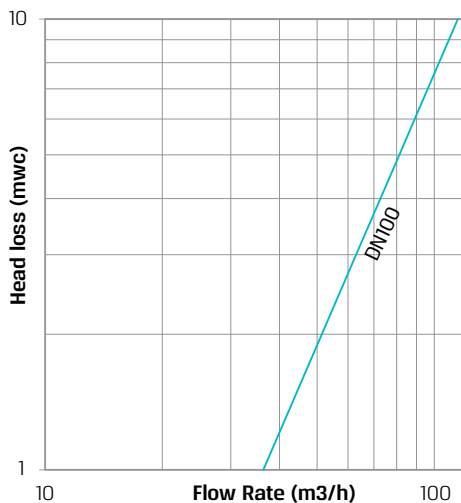

GEM-FLOW | G500

4" Hydraulic Valves

Hydraulic Specifications

Maximum continuous flow	100 m ³ /h
Maximum intermittent flow	145 m ³ /h
Minimum working pressure	0.7 bar
Maximum working pressure	10 bar
Kv	115 m ³ /h @ 1 bar

Dimensions

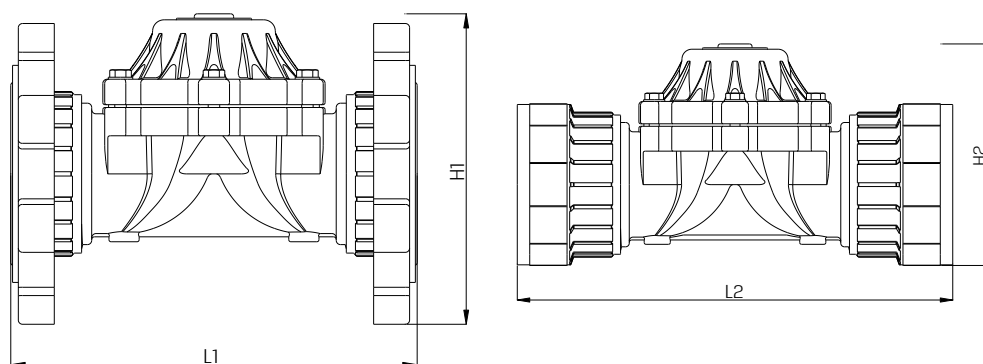

L1	280 mm
L2	350 mm
H1	220 mm
H2	180 mm
W1	213 mm
W2	172 mm
Port Connections	1/4" BSP, 1/4" NPT
Weight (Flange type)	2.6 kg
Weight (Threaded type)	1.9 kg

Available Applications

Basic valve	B
Manual control valve	M
Solenoid control valve	EL
Electric control valve + control device (1 outlet)	EL/C
Pressure reducing control valve	PR
Solenoid controlled pressure reducing valve	PREL
Pressure reducing & sustaining control valve	PRPS
Quick pressure relief control valve	QR
Pressure sustaining valve	PS
Float level control valve	FL
Electric float level control valve	FLEL
Flow rate control valve	FR

GEM-FLOW | G500-S

Hydraulic with Manual Selector 1-1/2" - 4"

Description

G500-S model valve is the hydraulic control valve operated by line pressure and designed to ensure opening/closing process by means of a 3 Way selector valve. Minimum opening pressure of valve is 0.7 bar. Thanks to its flexible diaphragm, it makes easy and fast control process in high pressure applications and is closed completely tight without causing surge. It may be used in different applications by adding different pilot valves on its main body.



Applications

- Use G500-S for local operation of hydraulic valve by a manual command
- Use G500-S for water distribution and field

Standards

- G500-S: manual control valve with 3 Way selector valve, polyethylene plastic tubing and nylon fittings

How to Order

G500	-	TYPE	-	PORT	
		Hydraulic	S	1-1/2" BSPT	70
		with Manual Selector	SM	1-1/2" NPT	71
				2" BSPT	80
				2" NPT	81
				2-1/2" BSPT	85
				2-1/2" NPT	86
				3" BSPT	90
				3" NPT	91
				4" BSPT	100
				4" NPT	101
				4" Flange	100F

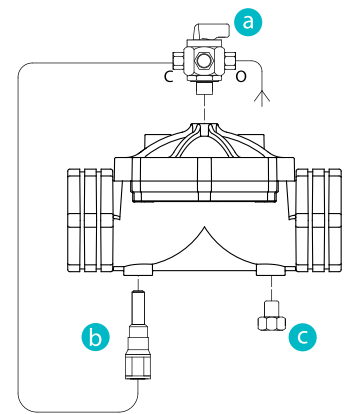

a 3W selector valve
b In-line finger filter
c Plug

Example: G500-SM-80
G500 Hydraulic with manual selector, 2" BSPT

G500 - SM - 80

* To order valves manufactured according to your specific requirements, please contact our technical sales department

GEM-FLOW | G500-EL

Electric Solenoid Control Valve 1-1/2" - 4"

Description

G500-EL model valve is the hydraulic control valve operated by line pressure and designed to ensure opening/closing process by means of built-in 3 Way solenoid pilot valve controlled remotely with electric signal*. Electric signal for solenoid pilot valve is ensured by means of a control device, time relay, main switch and PLC control units etc. Opening/Closing process may be realized easily thanks to manual control on solenoid pilot valve, depending on requirements, 24V AC 50Hz/60Hz or 12V DC, 9V Latch and 12V DC Latch normally open (NO) or normally closed (NC), solenoids coils may be used on main valve.

* For technical information, refer to G75-A and G75-A3P solenoid valves

Applications

- Use G500-EL to remove operation of hydraulic valve by an electric command
- Use G500-EL for water distribution

Standards

- G500-EL: 3 Way NO Solenoid, polyethylene plastic tubing system and nylon fittings
- G500-ELM: 3 Way NO Solenoid, polyethylene plastic tubing system, nylon fittings and 3 Way selector

How to Order

G500	-	TYPE	-	PORT	VOLTAGE		WIRES	
		Electric	EL	1-1/2" BSPT	70	No solenoid (hydraulic)	0	two null
		with Manual Selector	ELM	1-1/2" NPT	71	24V AC	1	three ⁽²⁾ a
				2" BSPT	80	24V AC w/out Diode	1R	
				2" NPT	81	12V AC	3	
				2-1/2" BSPT	85	12V DC	4	
				2-1/2" NPT	86	24V DC	5	
				3" BSPT	90	23Ω	6	
				3" NPT	91	4Ω	B	
				4" BSPT	100	9Ω	C	
				4" NPT	101	12Ω	D	
				4" Flange	100F	1Ω ⁽¹⁾	PA	
						4Ω ⁽¹⁾	PB	
						9Ω ⁽¹⁾	PC	

Example: G500-ELM-801

G500 Electric with manual selector, 2" BSPT, 24V AC, two wires

G500 - ELM - 80 - 1

- (1) For G75-A3P Latch
(2) For Latch only

* To order valves manufactured according to your specific requirements, please contact our technical sales department

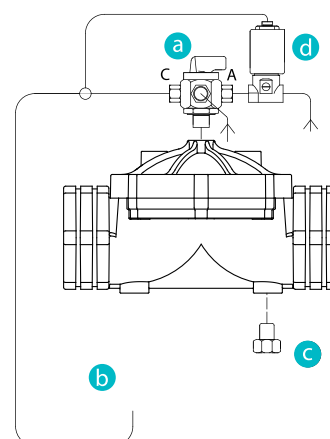

- a 3W selector valve
- b In-line finger filter
- c Plug
- d Solenoid Pilot Valve

GEM-FLOW | G500-C

DC Battery Controller 1-1/2" - 4"

Description

G500-C model valve is the hydraulic control valve operated by line pressure and designed to ensure opening/closing process by means of built-in solenoid pilot valve controlled remotely with electric signal at required time or required duration. Electric signal for solenoid pilot valve is ensured by means of a control device, time relay, main switch and PLC control units etc. Opening/ Closing process may be realized easily thanks to manual control on solenoid pilot valve, depending on requirements. The controller irrigates in cycles, during a window of time according to your needs.

Applications

- Use G500-C for programmed irrigation
- Use G500-C for water distribution

Standards

- G500-C: 9V DC Latch solenoid, Control Unit (1 Outlet), polyethylene plastic tubing system, nylon fittings and 3 Way selector

How to Order

G500-C	-	TYPE	-	PORT
One valve		null		1-1/2" BSPT 70
Window		W		1-1/2" NPT 71
Window +		W+		2" BSPT 80
				2" NPT 81
				2-1/2" BSPT 85
				2-1/2" NPT 86
				3" BSPT 90
				3" NPT 91
				4" BSPT 100
				4" NPT 101
				4" Flange 100F

Example: G500-C-W-90
G500 DC Battery controller,
Window, 3" BSPT

G500-C - W - 90

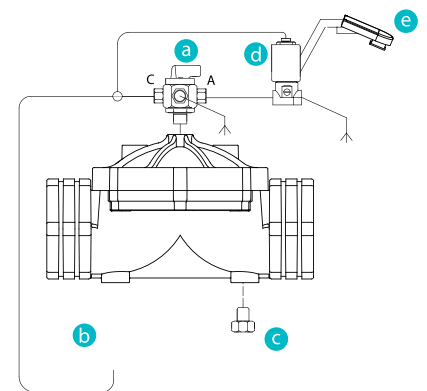

- a 3W selector valve
- b In-line finger filter
- c Plug
- d Solenoid Pilot Valve
- e Controller

* To order valves manufactured according to your specific requirements, please contact our technical sales department

GEM-FLOW | G500-PR

Pressure Reducing 1-1/2" - 4"

Description

G500-PR model pressure reducing control valve is the hydraulic control valve which reduces high upstream pressure value to desired lower pressure value by means of built-in pressure reducing pilot valve. Pressure reducing control valve controls downstream pressure value continuously and maintains it constant without being affected from flow rate and upstream pressure values. When no flow exists in the system, it closes itself automatically. When valve upstream pressure value is lower than set point, it is opened fully by itself. Valve may be used in vertical or horizontal positions in the system.



Applications

- Use G500-PR for irrigation, water distribution and filtration systems
- Smart designed G500-PR provides high corrosion resistance

Standards

- G500-PR: 3 Way plastic pressure reducing pilot, polyethylene plastic tubing system and nylon fittings
- G500-PRM: 3 Way plastic pressure reducing pilot, polyethylene plastic tubing system, nylon fittings and 3 Way selector
- Standard pressure adjustment from factory: 2.5 bar

How to Order

G500	TYPE	PORT	PRESSURE RANGE
	without Manual Selector PR	1-1/2" BSPT 70	0.5-5 bar Y
	with Manual Selector PRM	1-1/2" NPT 71	1-10 bar G
		2" BSPT 80	
		2" NPT 81	
		2-1/2" BSPT 85	
		2-1/2" NPT 86	
		3" BSPT 90	
		3" NPT 91	
		4" BSPT 100	
		4" NPT 101	
		4" Flange 100F	

Example: G500-PR-80G

G500 pressure reducing without manual selector, 2" BSPT, 1-10 bar

G500	-	PR	-	80	-	G
------	---	----	---	----	---	---

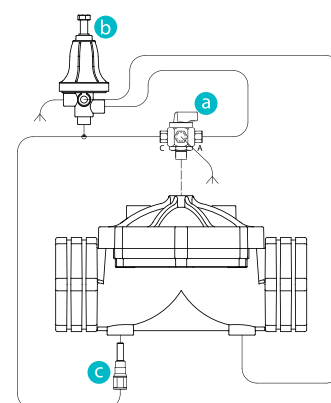

- a 3W selector valve
- b Plastic Pilot
- c In-line finger filter

* To order valves manufactured according to your specific requirements, please contact our technical sales department

GEM-FLOW | G500-PREL

Solenoid Controlled Pressure Reducing 1-1/2" - 4"

Description

G500-PREL model pressure reducing valve is the hydraulic control valve which reduces high upstream pressure value into desired lower pressure value. Control of main valve is achieved by means of built-in solenoid pilot valves*. Electric signal for solenoid pilot valves is ensured by means of a control device, time relay, main switch and PLC control units etc. Automated control may be easily ensured by this way in application systems.

* For technical information, refer to G75-A and G75-A3P solenoid valves



Applications

- Use G500-PREL for water distribution, where downstream pressure should be reduced, the valve is commanded to open

Standards

- G500-PREL: 3 Way plastic pressure reducing pilot, solenoid 24V AC NO, polyethylene plastic tubing system and nylon fittings
- G500-PRELM: 3 Way plastic pressure reducing pilot, solenoid 24V AC NO, polyethylene plastic tubing system and nylon fittings and 3 Way selector
- Standard pressure adjustment from factory: 2.5 bar

How to Order

G500	-	TYPE	-	PORT	VOLTAGE	WIRES	PRESSURE RANGE
		without Manual Selector	PREL	1-1/2" BSPT 70	No solenoid (hydraulic)	0	two null 0.5-5 bar Y
		with Manual Selector	PRELM	1-1/2" NPT 71	24V AC	1	three (2) a 1-10 bar G
				2" BSPT 80	24V AC w/out Diode	1R	
				2" NPT 81	12V AC	3	
				2-1/2" BSPT 85	12V DC	4	
				2-1/2" NPT 86	24V DC	5	
				3" BSPT 90	23Ω	6	
				3" NPT 91	4Ω	B	
				4" BSPT 100	9Ω	C	
				4" NPT 101	12Ω	D	
				4" Flange 100F	1Ω (1)	PA	
					4Ω (1)	PB	
					9Ω (1)	PC	

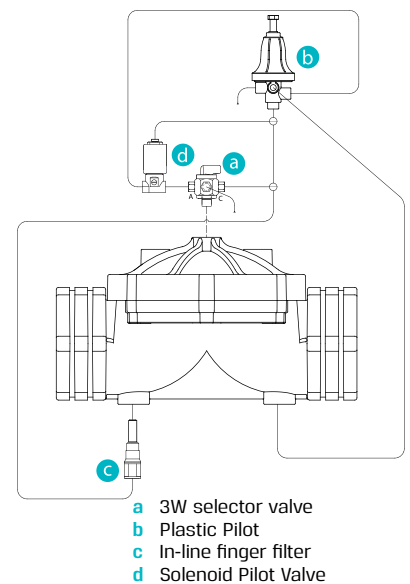

Example: G500-PRELM-851G

G500 Solenoid controlled pressure reducing, with manual selector, 2-1/2" BSPT, 24V AC, two wires, 1-10 bar



- (1) For G75-A3P Latch
 (2) For Latch only

* To order valves manufactured according to your specific requirements, please contact our technical sales department

GEM-FLOW | G500-PRPS

Pressure Reducing & Sustaining Control Valve 1-1/2" - 4"

Description

G500-PRPS model pressure reducing/sustaining hydraulic control valve reduces valve downstream pressure to desired value by sustaining upstream pressure. Two pilot valves exist on the valve. Pilot valve on upstream side is the pressure sustaining pilot valve and sustains upstream pressure. The other pilot valve is pressure reducing pilot valve and keeps downstream pressure constant by reducing it to desired value. Reducing/sustaining control valve pumps fluid downwards; it ensures that the system works within normal values by regulating overflow and high pressure in pumping systems. It controls upstream and downstream pressure continuously and keeps them within constant values.



Applications

- Use G500-PRPS for protecting booster pumps and preserving set pressure downstream

Standards

- G500-PRPS: 3 Way plastic pressure reducing pilot, 3 Way plastic pressure sustaining valve, polyethylene plastic tubing system, nylon fittings and 3 Way selector

How to Order

G500-PRPS	-	PORT		PRESSURE RANGE	
		1-1/2" BSPT	70	0.5-5 bar	Y
		1-1/2" NPT	71	1-10 bar	G
		2" BSPT	80		
		2" NPT	81		
		2-1/2" BSPT	85		
		2-1/2" NPT	86		
		3" BSPT	90		
		3" NPT	91		
		4" BSPT	100		
		4" NPT	101		
		4" Flange	100F		

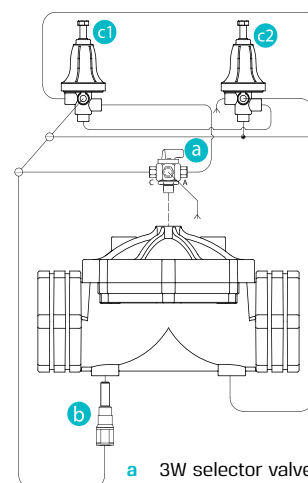

- a 3W selector valve
- b In-line finger filter
- c1 Plastic Pressure Sustaining Pilot
- c2 Plastic Pressure Reducing Pilot

Example: G500-PRPS-80G

G500 pressure reducing & sustaining 2" BSPT, 1-10 bar

G500-PRPS - 80 - G

* To order valves manufactured according to your specific requirements, please contact our technical sales department

GEM-FLOW | G500-QR

Quick Pressure Relief 1-1/2" - 4"

Description

G500-QR model quick pressure relief valve is the safety control valve designed to protect the system by releasing pressure surges, which are caused by sudden changes in water speed due to pumps put into/out of service, in water network elevation lines to the atmosphere quickly. When network pressure exceeds set point, the valve opens by itself quickly and protects the system by releasing over pressure. When the line pressure decreases to normal level, it is tightly closed slowly and automatically without causing a surge.

* For technical information, refer to G75-A and G75-A3P solenoid valves



Applications

- Use G500-QR when wishing to avoid unwanted high pressure

Standards

- G500-QR: 3 Way plastic pilot, polyethylene plastic tubing system and nylon fittings
- G500-QRM: 3 Way plastic pilot, polyethylene plastic tubing system and nylon fittings and 3 Way selector

How to Order

G500	TYPE	PORT	VOLTAGE	WIRES	PRESSURE RANGE
	without Manual Selector QR	1-1/2" BSPT 70	No solenoid (hydraulic)	0	0.5-5 bar Y
	with Manual Selector QRM	1-1/2" NPT 71	24V AC	1	1-10 bar G
		2" BSPT 80	24V AC w/out Diode	1R	
		2" NPT 81	12V AC	3	
		2-1/2" BSPT 85	12V DC	4	
		2-1/2" NPT 86	24V DC	5	
		3" BSPT 90	23Ω	6	
		3" NPT 91	4Ω	B	
		4" BSPT 100	9Ω	C	
		4" NPT 101	12Ω	D	
		4" Flange 100F	1Ω ⁽¹⁾	PA	
			4Ω ⁽¹⁾	PB	
			9Ω ⁽¹⁾	PC	

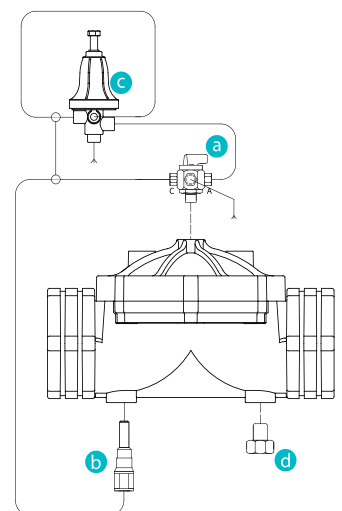

a 3W selector valve
b In-line finger filter
c Plastic Pilot
d Plug

Example: G500-QR-701G

G500 quick pressure relief, without manual selector, 1-1/2" BSPT, 24V AC, two wires, 1-10 bar



- (1) For G75-A3P Latch
(2) For Latch only

* To order valves manufactured according to your specific requirements, please contact our technical sales department

GEM-FLOW | G500-PS

Pressure Sustaining Control Valve 1-1/2" - 4"

Description

G500-PS model pressure sustaining hydraulic control valve maintains valve upstream pressure value constant. Valve is opened when line pressure reaches the preset pressure level. It ensures that pump motor within pumping systems will start without load. It also prevents positive pressure waves caused by pump during start-up. The valve controls upstream pressure value continuously and keeps it at a constant value without being affected from changes in flow rate. When no flow exists, it closes tightly by itself.

* For technical information, refer to G75-A and G75-A3P solenoid valves



Applications

- Use G500-PS for maintaining a constant upstream pressure or to avoid unwanted high pressure

Standards

- G500-PS: 3 Way plastic pressure sustaining pilot, polyethylene plastic tubing system and nylon fittings
- G500-PSM: 3 Way plastic pressure sustaining pilot, polyethylene plastic tubing system, nylon fittings and 3 Way selector
- Standard pressure adjustment from factory: 2.5 bar

How to Order

G500	-	TYPE	-	PORT		VOLTAGE		WIRES		PRESSURE RANGE
		without Manual Selector	PS	1-1/2" BSPT	70	No solenoid (hydraulic)	0	two	null	0.5-5 bar Y
		with Manual Selector	PSM	1-1/2" NPT	71	24V AC	1	three ⁽²⁾	a	1-10 bar G
				2" BSPT	80	24V AC w/out Diode	1R			
				2" NPT	81	12V AC	3			
				2-1/2" BSPT	85	12V DC	4			
				2-1/2" NPT	86	24V DC	5			
				3" BSPT	90	23Ω	6			
				3" NPT	91	4Ω	B			
				4" BSPT	100	9Ω	C			
				4" NPT	101	12Ω	D			
				4" Flange	100F	1Ω ⁽¹⁾	PA			
						4Ω ⁽¹⁾	PB			
						9Ω ⁽¹⁾	PC			

Example: G500-PSM-801G

G500 pressure sustaining with manual selector, 2" BSPT, 24V AC, two wires, 1-10 bar

G500 - PSM - 80 - 1 - G

(1) For G75-A3P Latch

(2) For Latch only

* To order valves manufactured according to your specific requirements, please contact our technical sales department

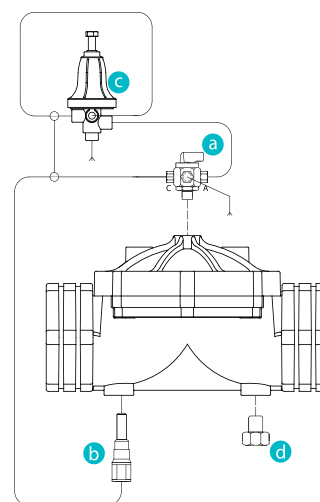

- a 3W selector valve
- b In-line finger filter
- c Plastic Pilot
- d Plug

b **BACCARA**[®]
AUTOMATION & CONTROL



CONTROLLERS & SPECIAL

VALVES

GEM-FLOW OCTOPUS	Automatic Filter, Filter Backwash.....	84
GEM-FLOW ii.ri-C	Smart Irrigation Controller 2 Way.....	86
GEM-FLOW ii.ri-C-VSA	Smart Irrigation Controller 3 Way.....	88
GEM-FLOW G75-C	Irrigation Controller 1, 2 & 4 Valves.....	90
GEM-FLOW G75-C-1W & 1W+	Irrigation Window Controller.....	92
GEM-FLOW G75-DP	Baccara Differential Pressure Gauge Switch.....	94
GEM-FLOW G75-DFC-DC	Baccara Filtration Controller Set (DFC).....	95
GEM-FLOW G75-BWM	Baccara Water Meter Controller.....	96
GEM-FLOW G75-DLS	Digital Level Switch.....	97
GEM-FLOW G75-ADP	Baccara Analog Differential Pressure Sensor.....	98
GEM-SOL GEM-LDO	Long Distance Operator 2 Way, 3 Way NC, NO.....	99
GEM-SOL LDOS	Long Distance Operating Solenoid.....	100
GEM-FLOW G75-LDO	Long Distance Operator 2 Way, 3 Way NC, NO.....	101



GEM-FLOW | OCTOPUS

Automatic Filter, Filter Backwash

The Octopus is a new innovative Automatic Filter Backwash Controller, operated and monitored by a Smartphone via a unique Application.

The Octopus backwashes in two operating modes: by measuring the differential pressure (DP) and by time intervals, both operated by unique pressure sensors connected to the inlet and outlet of the filtration system.

The Octopus App enables the user to set backwash parameters and alerts. It also provides important real-time data such as:

- Backwash counters
- Upstream/downstream pressures
- DP readings
- Battery status
- Full datalogging recording of: time & date, backwash cycles, system alerts, and pressure reading logs.



Features & Benefits

- Controls various automatic filtration systems: Media, Disc, Screen
- Backwash triggers: (each backwash cycle resets the time interval counter)
 - Differential Pressure up to 10 bars
 - Time Interval
 - Manual Start Command
- Capable of backwashing up to 10 filters
- Wireless communication between the controller and the smartphone
- Alarm and Backwash outputs for communicating with irrigation controllers
- Downloadable datalogger Date & Time records: DP / backwash intervals / manual starts / malfunctions / upstream & downstream pressure readings
- Consecutive backwash cycles protection settings
- Battery status and low battery alarms
- Various App Languages
- Integrated upstream and downstream pressure sensors

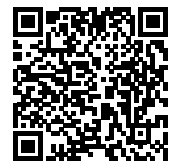

IOM OCTOPUS



Technical Data

- Construction Materials: UV Resistant ASA
- Temperature range: -10°C to 60°C
- IP 65
- Power supply: (1-10): 8 x C type, or 12VDC
(1-3): 6 x C type, or 12VDC
- Outputs: 1-3 DC Latch + Downstream valve
- Outputs: 1-10 DC Latch + Downstream valve
- Dimensions Octopus10: Depth: 97 mm / 3.82 inch
Height: 190mm / 7.48 inch
Width: 140mm / 5.51 inch
- Dimensions Octopus3: Depth: 97 mm / 3.82 inch
Height: 160mm / 6.3 inch

Applications

- Agriculture and Greenhouse filtration systems
- Landscape and Turf filtration systems

Models

-  **OCTOPUS10** Filter Backwash Controller Octopus 10 for 1-10 filters + downstream valve
-  **OCTOPUS3** Filter Backwash Controller Octopus3 for 1-3 filters + downstream valve Width: 140mm / 5.51 inch

The App

Available in 8 languages:

English | Arabic | French | German | Hebrew | Portuguese | Spanish | Turkish



Device manager



Home screen



Settings



Activity log



Alarm log

CONTROLLERS & SPECIAL VALVES



GEM-FLOW | ii.ri-C

Smart Irrigation Controller 2 Way



- Single station Irrigation Controller
- Wireless operated by smart device
- Four irrigation program types
- Minimum required iOS 7 or Android V4.3
- Battery included

Technical Data

Function	2 Way Latch
Pressure range	0 to 8 bar
Temperature range	Fluid: 5° to 50°C (no freezing) Ambient: -5° to 50°C
Communication protocol	Wireless BLE
App Downloading	 
Pairing code	Not required
Communication range	Up to 10 m (32.8 feet)
Battery type	CR123
Mounting	Direct mounting on UNEF 3/4"
Standard / Certification	<ul style="list-style-type: none"> • CE • Federal Communications Commission (FCC) • EN55011 Group1 - Class A / EN61000-6-1/ CFR 47 FCC Class A EMC- SII Certificate of Conformity
Standard protection class	• Dust and watertight IP68

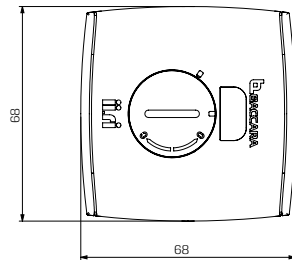
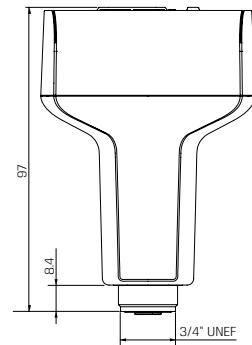

Programming Key Features

Four different irrigation plans

Weekly	Interval Days	Even / Odd Days	Window
Irrigation each day of the week	Periodical days up to 98 periods	Even / odd calendar dates	Repeated cycles within a defined time frame
Set up to 6 cycles per day			Set cycle On and Off duration
Option to set different irrigation durations per cycle			Set start and end times for irrigation

How to Order

ii.ri-C	PORT	FLOW CONTROL	COLOR
	None	with	Grey
	Null	5	CLOUD
	3/4" BSPT	without ⁽¹⁾	
	50	6	
	3/4" NPT		
	51		
	1" BSPT		
	60		
	1" NPT		
	61		
	1-1/2" BSPT		
	70		
	1-1/2" NPT		
	71		
	2" BSPT		
	80		
	2" NPT		
	81		

Example: ii.ri-C-51-6-CLOUD

ii.ri smart irrigation controller with 3/4" NPT valve, without flow control, color CLOUD

ii.ri-C - 51 - 6 - CLOUD

(1) For 3/4" and 1" valves only

* To order controllers manufactured according to your specific requirements, please contact our technical sales department

CONTROLLERS & SPECIAL VALVES



GEM-FLOW | ii.ri-C-VSA

Smart Irrigation Controller 3 Way



- Single station Irrigation Controller
- Wireless operated by smart device
- Four irrigation program types
- Minimum required iOS 7 or Android V4.3
- Battery included

Technical Data

Function	3 Way Latch
Pressure range	0 to 8 bar
Temperature range	Fluid: 5° to 50°C (no freezing) Ambient: -5° to 50°C
Communication protocol	Wireless BLE
App Downloading	 
Pairing code	Not required
Communication range	Up to 10 m (32.8 feet)
Battery type	CR123
Mounting	Direct mounting on UNEF 3/4"
Standard / Certification	<ul style="list-style-type: none"> • CE • Federal Communications Commission (FCC) • EN55011 Group1 - Class A / EN61000-6-1/ CFR 47 FCC Class A • EMC- SII Certificate of Conformity
Standard protection class	• Dust and watertight IP68

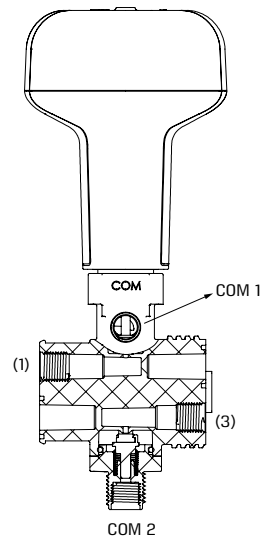

Programming Key Features

Four different irrigation plans

Weekly	Interval Days	Even / Odd Days	Window
Irrigation each day of the week	Periodical days up to 98 periods	Even / odd calendar dates	Repeated cycles within a defined time frame
Set up to 6 cycles per day			Set cycle On and Off duration
Option to set different irrigation durations per cycle			Set start and end times for irrigation

PORT	NO	NC
1	Exhaust	Pressure
3	Pressure	Exhaust
COM	Out	Out

Dimensions

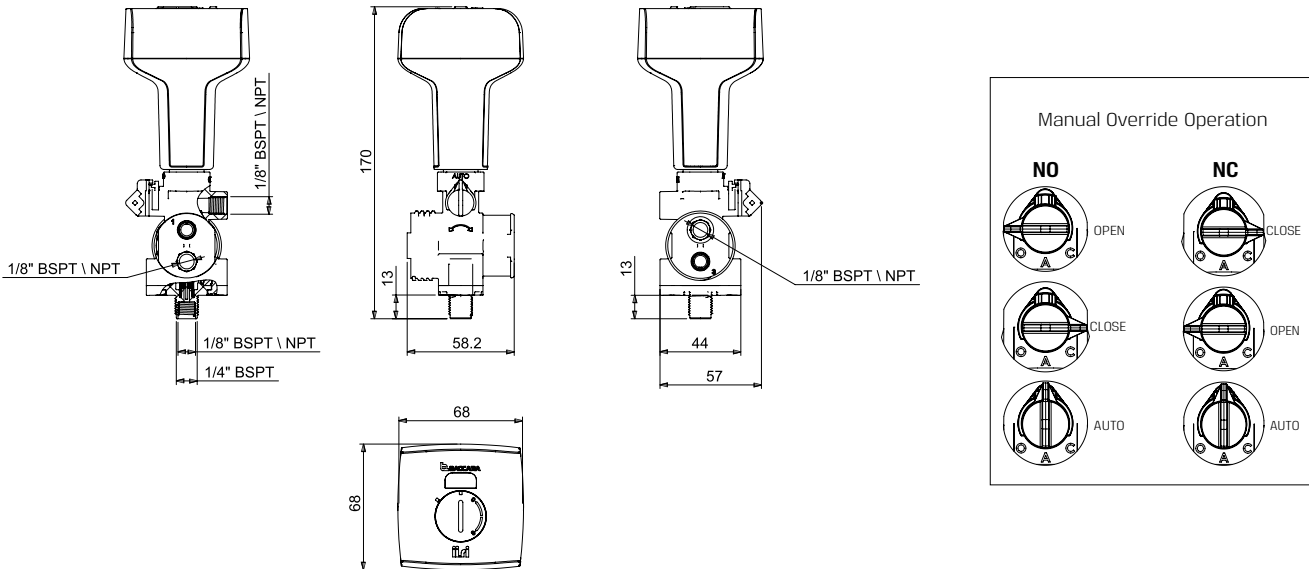

How to Order

ii.ri-C-VSA -	BODY	PORT	FUNCTION	SEALS
	Plastic	4	1/8" BSP 10	3W NC 3 EPDM E
			1/8" NPT 11	3W NO 4

Example: ii.ri-C-VSA-4103E

ii.ri smart irrigation controller with 1/8" BSP valve, 3W NC, EPDM seals

ii.ri-C-VSA - 4 10 3 E

* To order controllers manufactured according to your specific requirements, please contact our technical sales department

CONTROLLERS & SPECIAL VALVES

GEM-FLOW | G75-C

Irrigation Controller | 1, 2 & 4 Valves



Technical Data

Operating temperature	-10° to 60°C
Mounting	Various mounting options: <ul style="list-style-type: none"> • Directly on a 28mm diameter solenoid in horizontal or vertical position with adaptor • Wall mounting with four screws • Accessories provided
Electrical	Powered by single 9V alkaline battery; use best quality to ensure at least one year's autonomous operation. <ul style="list-style-type: none"> • Back-up memory • Low battery warning • Power saving LCD • Battery included
Solenoid	Compatible with G75 4Ω latch operator
Valve	Can operate any valve equipped with 3/4" UNEF solenoid cavity (Richdel® type)
Software	<ul style="list-style-type: none"> • 24 hours real time clock • See 'Programming key features' table
Options	<ul style="list-style-type: none"> • Solar panel • Charger • Accurate clock (low time drift)
Standard / Certification	CE
Standard protection class	<ul style="list-style-type: none"> • Dust and watertight • IP67 and NEMA 4X



G75 One Valve

G75 Two Valves

G75 Four Valves

Size	A	B	C
3/4"	145	110	81
1"	153	110	81
1-1/2"	166	160	127
2"	166	170	127

Mounting Options

Wall mounting



Horizontal mounting

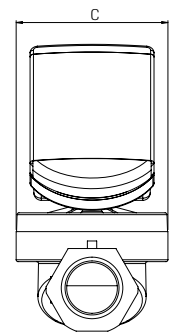
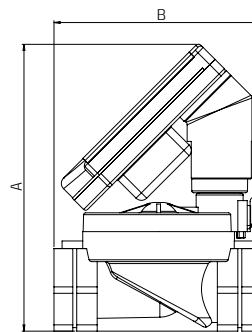

Programming Key Features

One Valve	Two Valves	Four Valves
Once daily, at the same time	Up to three starts per day	Up to three starts per day
Once daily on selected days	Starts select	Starts select
Three starts per day	Day select	Day select
OFF	Season adjustment 10% - 200%	Season adjustment 10% - 200%
	OFF	OFF
		Master valve will be opened for each command

How to Order

G75-C	-	TYPE OF CONTROLLER ⁽¹⁾	-	VALVE 1 ⁽¹⁾	
		One valve	1	No valve	00
		Two valves	2	1/2" BSP	40
		Four valves	4	1/2" NPT	41
				3/4" BSP	50
				3/4" NPT	51
				1" BSP	60
				1" NPT	61
				1-1/2" BSP	70
				1-1/2" NPT	71
				2" BSP	80
				2" NPT	81
				G75-A *	

TYPE	PORT	FUNCTION	MANUAL OVERRIDE	ORIFICE					
with flange	1	1/8" BSP	10	2W NC	1	None	0	1.0 ⁽²⁾	1
Brass	3	1/8" NPT	11	3W NC	3			1.2	2
		1/4" BSP ⁽²⁾	20	3W NO	4			1.6	3
		1/4" NPT ⁽²⁾	21						

* G75-A

1) Example: G75-C-160

GEVA 75 One Valve controller, 1" BSP

G75-C	-	1	-	60
-------	---	---	---	----

(1) Only for One valve controller type. Choose "00" for Two and Four valve controller types

(2) Brass only

* To order controllers manufactured according to your specific requirements, please contact our technical sales department

GEM-FLOW | G75-C-1W & 1W+

Irrigation Window Controller



Technical Data

Operating temperature	-10° to 60°C
Mounting	Various mounting options: <ul style="list-style-type: none"> • Directly on a 28mm diameter solenoid in horizontal or vertical position with adaptor • Wall mounting with four screws • Accessories provided
Electrical	Powered by single 9V alkaline battery; use best quality to ensure at least one year's autonomous operation. <ul style="list-style-type: none"> • Back-up memory • Low battery warning • Power saving LCD • Battery included
Solenoid	Both Window and Window+ controllers have identical programming. <ul style="list-style-type: none"> • Window: compatible with G75 4Ω latch operator • Window+: has a stronger output to operate G80 latch and GEM-SOL 'IL' latch coils
Valve	<ul style="list-style-type: none"> • Window: can operate any valve equipped with 3/4" UNEF solenoid cavity (Richdel® type) • Window+: only with Baccara latch valve
Software	<ul style="list-style-type: none"> • 24 hours real time clock • See 'Programming key features' table
Options	<ul style="list-style-type: none"> • Solar panel • Charger • Accurate clock (low time drift)
Standard / Certification	CE
Standard protection class	<ul style="list-style-type: none"> • Dust and watertight • IP67 and NEMA 4X



G75 Window +



Irrigation cycles within a defined time frame

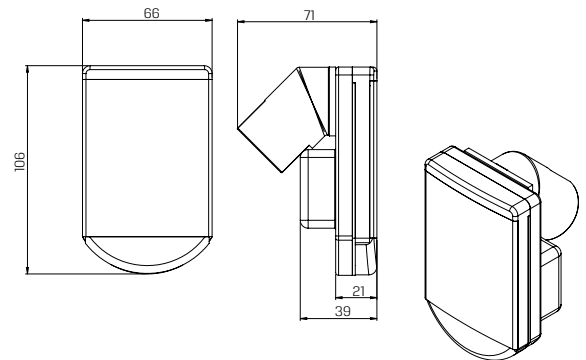

Mounting Options

Wall mounting



Horizontal mounting



Programming Key Features

Set start and end hours
Set On time (1 second to 12 hours)
Set Off time (1 min to 12 hours)
Day select
OFF

How to Order: G75 Window

G75-C-1W	-	VALVE
No valve		00
1/2" BSP		40
1/2" NPT		41
3/4" BSP		50
3/4" NPT		51
1" BSP		60
1" NPT		61
1-1/2" BSP		70
1-1/2" NPT		71
2" BSP		80
2" NPT		81
G75-A *		

TYPE	PORT	FUNCTION	MANUAL OVERRIDE	ORIFICE			
with flange	1	1/8" BSP	10	2W NC 1	None 0	1.0 ⁽¹⁾	1
Brass	3	1/8" NPT	11	3W NC 3		1.2	2
		1/4" BSP ⁽¹⁾	20	3W NO 4		1.6	3
		1/4" NPT ⁽¹⁾	21				

- * This controller will only operate with G75 operators
- * G75-A

Example: G75-C-1W-50

GEVA 75 Window controller with 3/4" BSP valve.

G75-C	-	1W	-	50
-------	---	----	---	----

(1) Brass only

How to Order: G75 Window+

G75-C-1W ⁺	-	VALVE
Refer to How to Order section of GEM-SOL valves. Consult with us to discuss your specific requirements.		

Example: G75-C-1W+-GEM-A-21045N0

GEVA 75 Window+ controller with: GEM-A valve, brass, 1/8" BSP, 3W NO, 2.4 orifice, NBR, no manual override.

G75-C-1W ⁺	-	GEM-A	-	2	-	10	-	4	-	5	-	N	-	0
-----------------------	---	-------	---	---	---	----	---	---	---	---	---	---	---	---

* To order controllers manufactured according to your specific requirements, please contact our technical sales department

GEM-FLOW | G75-DP

Baccara Differential Pressure Gauge Switch

- Reads and reacts to pressure differential between two reading points
- Suitable to work with both media - air and liquid
- Main applications: filters backwash, pumps control, pressure control

Technical Data

Mechanical	<ul style="list-style-type: none"> • Operating temperature: -10°C to 60°C (no freezing) • Outdoor UV protection • Front panel cover protection • "H" proof pressure: 14 bar (203 PSI) • "H" pressure must be \geq "L" pressure.
Electrical	<ul style="list-style-type: none"> • Power supply: 6-24V DC or 12-24V AC • RED + BLK power supply • GRN / WHT N.O contact • Low power detect • Dry contact (N.O) 0.5A at 24V AC • Internal memory to retain "set-up data" at power down.
Mounting	<ul style="list-style-type: none"> • 2" (52mm) diameter • 2ft (60cm) 4 wires cable • Pressure ports 1/8" BSP/NPT (male) • High pressure port is marked by the letter "H" on the housing • Connect high pressure before low pressure • Disconnect low pressure before high pressure
Software	See 'Programming key features' table
Display	<p>The LCD display:</p> <ul style="list-style-type: none"> • DIF: measured differential pressure • SET: pressure differential trigger setting • ON: displayed when the switch contacts are closed <p>Display resolution:</p> <p>1 PSI in the range 0 - 99 psi 0.1 bar in the range 0.0 - 7 bar</p>
Standard protection class	<ul style="list-style-type: none"> • Dust and watertight • IP66

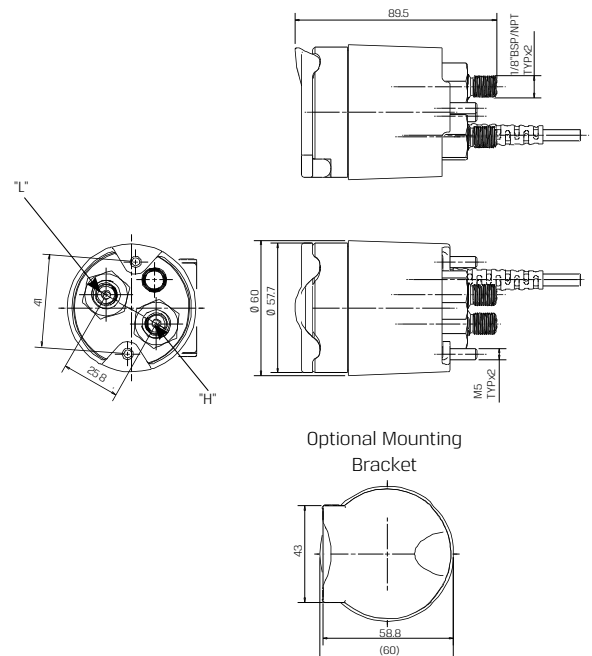

How to Order

G75-DP	-	TYPE	ACCESSORIES
		Stand alone	1 Mounting bracket B

Example: G75-DP-1B

Baccara Differential Pressure Gauge switch, stand alone with mounting bracket



Programming Key Features

Manual operation
PSI or bar display
Time interval between pressure measurements
Contact closed time
Time interval between contact closure
Zero calibration

* To order special valves manufactured according to your specific requirements, please contact our technical sales department

GEM-FLOW | G75-DFC-DC

Baccara Filtration Controller Set (DFC)

- Filtration backwash controller 1-3 stations
- Main valve output is optional
- Backwash by DP or time interval
- The assembly includes controller and differential pressure sensor
- Mounting bracket optional

Technical Data

Controller Set Supplied with	DFC controller, suitable for DC only, and one analog sensor
Mechanical	<ul style="list-style-type: none"> • Operating temperature: -10°C to 60°C • Outdoor UV protection • Front panel cover protection • "H" proof pressure: 14 bar (203 PSI) • "H" pressure must be \geq "L" pressure.
Electrical	<p>DC units are powered by single 9V alkaline battery; use best quality to ensure at least one year's autonomous operation.</p> <ul style="list-style-type: none"> • Back-up memory • Low battery warning • Power saving LCD
Mounting	<ul style="list-style-type: none"> • Pressure ports 1/8" BSP/NPT (male) • High pressure port is marked by the letter "H" on the housing • Connect high pressure before low pressure • Disconnect low pressure before high pressure <p>Controller:</p> <ul style="list-style-type: none"> • Directly on a 28mm diameter solenoid in horizontal or vertical position with adaptor • Wall mounting with four screws • Accessories provided Sensor: 2" (52 mm diameter)
Software	See 'Programming key features' table
Options	Option to change default factory settings
Standard protection class	• IP66 Dust and watertight
Solenoid	G75-A, GALIT Latch 4 Ω , G75-A3P 1 Ω



Programming Key Features

Manual operation
Valve ON time
Maximum time interval between washes
Valve selection

How to Order

G75-DFC-DC	-	TYPE	-	MOUNTING BRACKET
		3 Valves	0	without 0
		3 Valves + 1 Main Valve	1	with 1

Example: G75-DFC-DC-1-1

G75-DFC-DC, 3 Valves + 1 Main valve, with mounting bracket

G75-DFC-DC	-	1	-	1
------------	---	---	---	---

* To order controllers manufactured according to your specific requirements, please contact our technical sales department

GEM-FLOW | G75-BWM

Baccara Water Meter Controller

- Single station water volume controller
- Connected to a water meter with pulse outlet
- Opens at a set time and closes when required water volume has been reached

Technical Data

Operating temperature	-10° to 60°C
Electrical	Powered by single 9V alkaline battery; use best quality to ensure at least one year's autonomous operation. <ul style="list-style-type: none"> • Back-up memory • Low battery warning • Power saving LCD • Battery included
Mounting	Various mounting options: <ul style="list-style-type: none"> • Directly on a 28mm diameter solenoid in horizontal or vertical position with adaptor • Wall mounting with four screws • Accessories provided
Solenoid	Compatible with G75 4Ω latch operator
Measurement units per pulse	100 liters 1m ³ 10m ³ 100 gallons 1000 gallons
Software	<ul style="list-style-type: none"> • 24 hours real time clock • See 'Programming key features' table
Options	Solar panel, charger
Standard protection class	<ul style="list-style-type: none"> • Dust and watertight • IP67 and NEMA 4X

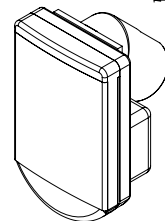
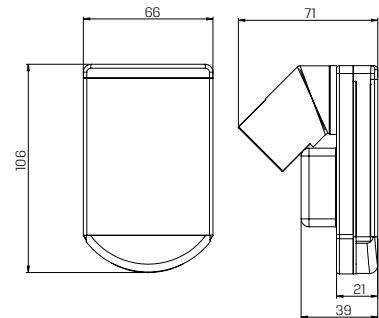

How to Order

G75-BWM	VALVE	TYPE	PORT	FUNCTION	MANUAL OVERRIDE	ORIFICE
No valve	00	with flange	1 1/8" BSP	10 2W NC	1 None	0 1.0 ⁽¹⁾ 1
1/2" BSP	40	Brass	3 1/8" NPT	11 3W NC	3	1.2 2
1/2" NPT	41		1/4" BSP ⁽¹⁾	20 3W NO	4	1.6 3
3/4" BSP	50		1/4" NPT ⁽¹⁾	21		
3/4" NPT	51					
1" BSP	60					
1" NPT	61					
1-1/2" BSP	70					
1-1/2" NPT	71					
2" BSP	80					
2" NPT	81					
G75-A *						

* G75-A

Example: G75-BWM-G75-A-110102

G75-A with flange, 1/8" BSP, 2W NC, no manual override, 1.2 orifice



(1) Brass only

Programming Key Features

Set start time
Set required water volume
Day select
OFF

* To order controllers manufactured according to your specific requirements, please contact our technical sales department

GEM-FLOW | G75-DLS

Digital Level Switch

- Measuring level of two set points: top and bottom
- Gives a signal to pump or valve
- Dry installation - no elements inside the tank
- Main applications: filling or draining of water reservoir and tanks

Technical Data

Mechanical	<ul style="list-style-type: none"> • Operating temperature: -10°C to 60°C (no freezing) • Outdoor UV protection • Front panel cover protection
Electrical	<ul style="list-style-type: none"> • Power supply: 6-24V DC or 12-24V AC • RED + BLK power supply • GRN / WHT N.O contact • Low power detect • Dry contact (N.O) 0.5A at 24V AC • Internal memory to retain "set-up data" at power down.
Mounting	<ul style="list-style-type: none"> • 2" (52mm) diameter • 2ft (60cm) 4 wires cable • Pressure ports 1/8" BSP/NPT (male) • High pressure port is marked by the letter "H" on the housing • Connect the water tank to the "H" port only
Software	See 'Programming key features' table
Display	<ul style="list-style-type: none"> • The LCD display shows the water level above the DLS mounting place • "ON" is displayed when the switch contacts are closed <p>Display resolution:</p> <ul style="list-style-type: none"> • 10 cm in a range of 0.0 - 70.0m • 0.01 bar in the range 0.0 - 7 bar
Standard protection class	<ul style="list-style-type: none"> • Dust and watertight • IP66

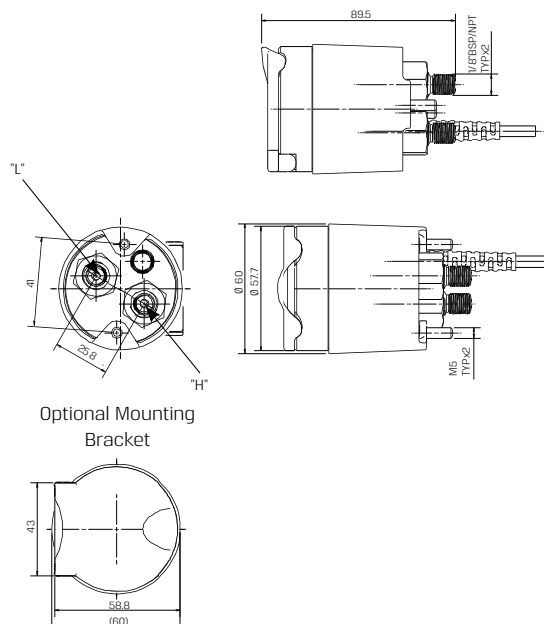

How to Order

G75-DLS	-	TYPE	ACCESSORIES
		Stand alone	1 Mounting bracket B

Example: G75-DLS-1B

Digital Level switch, stand alone, with mounting bracket

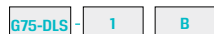

Programming Key Features

Manual operation
Time interval between level measurements function
Function: "SET" for fill "RESET" for empty
Zero calibration

* To order special valves manufactured according to your specific requirements, please contact our technical sales department

GEM-FLOW | G75-ADP

Baccara Analog Differential Pressure Sensor

- Differential pressure to current transducer
- Suitable to work with both media - air and liquid
- Main application: analog sensor for filters backwash

Technical Data

Mechanical	<ul style="list-style-type: none"> • Operating temperature: -10°C to 60°C (no freezing) • Outdoor UV protection • Measuring pressure range: 0-7 bar (0-101.5 PSI) • "H" proof pressure: 14 bar (203 PSI) • "H" pressure must be ≥ "L" pressure
Electrical	<ul style="list-style-type: none"> • Power supply: 5V DC • RED: (+) 5V • BLACK: (-) 5V • ORANGE: analog output • Analog output value: 0.2V to 4.7V, [V out = (0.006429xKpa+0.2)± Error] • Output accuracy: 2.5% of full scale
Mounting	<ul style="list-style-type: none"> • 2" (52mm) diameter • 2ft (60cm) 3 wires cable • Pressure ports 1/8" BSP/NPT (male) • High pressure port is marked by the letter "H" on the housing • Connect high pressure before low pressure • Disconnect low pressure before high pressure
Standard protection class	<ul style="list-style-type: none"> • IP66

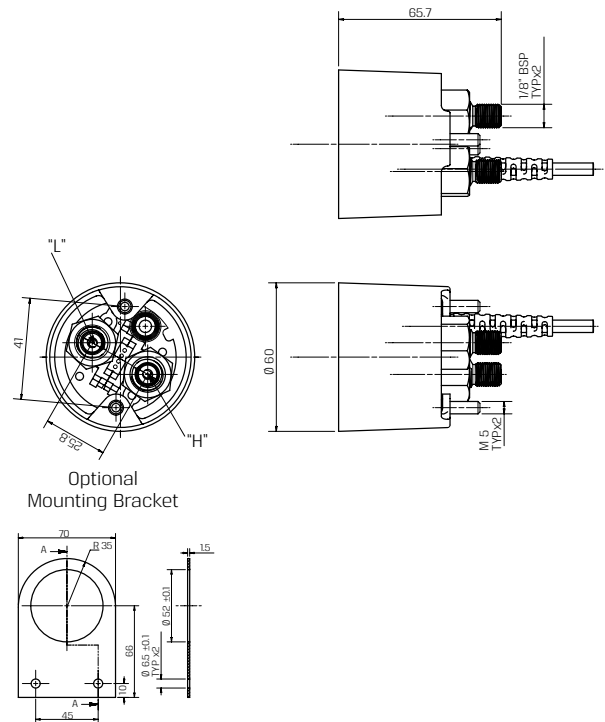

How to Order

G75-ADP	-	TYPE	MOUNTING BRACKET
		Stand alone	1
			without
			with

Example: G75-ADP-10
 Baccara Analog Differential Pressure sensor,
 stand alone, without mounting bracket



* To order controllers manufactured according to your specific requirements, please contact our technical sales department

GEM-SOL | GEM-LDO

Long Distance Operator 2 Way, 3 Way NC, NO

Technical Data

Function	2 Way, 3 Way NC, NO
Current	Holding 4mA
Pressure range	Refer to working pressure definitions of the valve that the GEM-LDO is assembled on, with DC10W/AC8W
Power	<ul style="list-style-type: none"> • DC12V (0.05W) up to DC24V (0.1W) • 24V AC: 0.3W
Connection	Red/Black - power supply Green/Black - coil Lead wire length - 28cm PVC coated AWG 18 UL 1007
Ambient temp	-10°C to 70°C
Operation	Only with GEM-BL-LDO coil and Baccara valve
Applications	<ul style="list-style-type: none"> • Cost saving wiring for remote solenoid operation • Power saving and heat prevention on continuous energized solenoid
Voltage	Voltage and power consumption - see table
Standard protection class	IP67 (LDO only)



LDO unit

A small section conductor can be used at a distance of up to 5 kms

* For recommended wire parameters, please refer to Long distance operators charts

Voltage	Distance (km)	Conduit section (mm ²)	Delay Time (sec)	
			On	Off
12/24	5	0.5	3	1

* Max conduit resistance 390 at nominal voltage

Voltage & Power Consumption

V	AC (W)		DC(W)	
	50 Hz	60 Hz	0.05	0.1
12	•	•	•	•
24	•	•	•	•

• Available options



Assembled with GEM-A solenoid



Assembled with GEM-S solenoid

How to Order

GEM-LDO - VOLTAGE - Please refer to the "How to Order" definitions of the assembled GEM-SOL valve.

24 VAC & 12-24 VDC 9

Example: GEM-LDO-9-GEM-A-21035NO

GEM-LDO is attached to a GEM-SOL latch coil direct operated, brass 1/8"BSP, 3W NC, 2.4 orifice, NBR, no manual override

GEM-LDO - 9 - GEM-A - 2 - 10 - 3 - 5 - N - 0

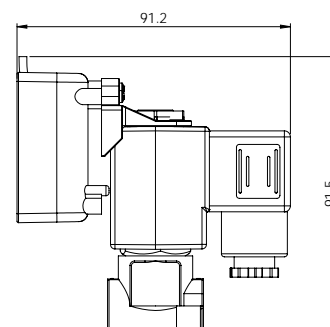
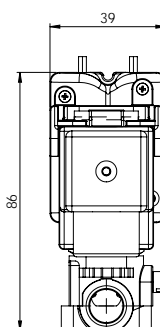

* To order special valves manufactured according to your specific requirements, please contact our technical sales department

GEM-SOL | LDOS

Long Distance Operating Solenoid

Technical Data

Current	24V AC: Inrush 210mA Holding 18mA 12V DC: Inrush 120mA Holding 5mA
Pressure range	See table
Delay time	See table
Connection	DIN 43650 Connecting box
Ambient temp	-10°C to 70°C
Operation	Only with a Baccara valve
Applications	<ul style="list-style-type: none"> • Cost saving wiring for remote solenoid operation • Power saving and heat prevention on continuous energized solenoid
Voltage	<ul style="list-style-type: none"> • Voltage and power consumption - see table • +10% -10% of nominal
Standard protection class	IP65 with connector

* For recommended wire parameters, please refer to Long distance operators charts



LDOS unit
A small section conductor can be used at a distance of up to 5 kms.

Pressure (bar)

Function	Orifice (mm)	Pressure
3 Way NC	1.6	16
	2.0	10
	2.4	8
3 Way NO	1.6	16
	2.0	12
	2.4	8

Delay time (sec) at a nominal voltage	Distance (Km)	Conduit Section (mm)
4-5	2.4	0.5
	4.8	1.0
	7.5	1.5



Assembled with GEM-S solenoid Assembled with GEM-A solenoid

Voltage & Power Consumption

V	AC (W)		DC (W)
	50 Hz	60 Hz	
12			•
24	•	•	

• Available options

How to Order

LDOS	-	VOLTAGE	-	Please refer to the "How to Order" definitions of the assembled GEM-SOL valve
		24V AC	1	
		12V DC	2	

Example: LDOS-1-GEM-A-21035N0

LDOS 24V AC is attached to a GEM-SOL latch coil direct operated, brass, 1/8"BSP, 3W NC, 2.4 orifice, NBR, no manual override

LDOS	-	1	-	GEM-A	-	2		10		3		5		N		0
------	---	---	---	-------	---	---	--	----	--	---	--	---	--	---	--	---

* To order special valves manufactured according to your specific requirements, please contact our technical sales department

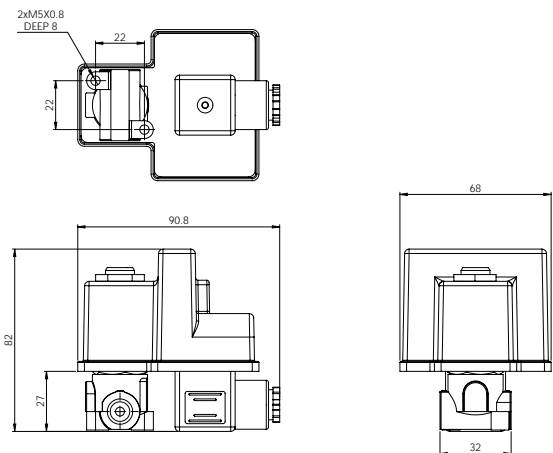

GEM-FLOW | G75-LDO

Long Distance Operator 2 Way, 3 Way NC, NO

Technical Data

Function	2 Way, 3 Way NC, NO
Current	Holding 4mA
Pressure range	Refer to G75 Latch operator
Power	DC12V (0.05W) up to DC24V (0.1W)
Connection	Red/Black - power supply Green/Black - coil
Ambient temp	-10°C to 60°C
Solenoid	Compatible with G75 4Ω latch operator
Valve	Can operate any valve equipped with 3/4" UNEF solenoid cavity (Richdel® type).
Applications	<ul style="list-style-type: none"> • Cost saving wiring for remote solenoid operation • Power saving and heat prevention on continuous energized solenoid
Voltage	Voltage and power consumption - see table
Standard protection class	IP67 (LDO only)



LDO unit assembled with G75-A operator and solenoid
A small section conductor can be used at a distance of up to 5 kms

* For recommended wire parameters, please refer to Long distance operators charts

Voltage	Distance (km)	Conduit section (mm ²)	Delay time (sec)	
			On	Off
12/24	5	0.5	3	1

* Max conduit resistance 390 at nominal voltage

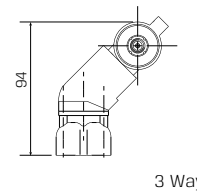
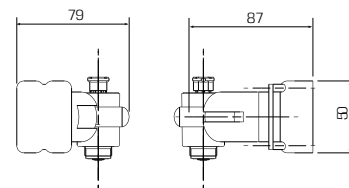
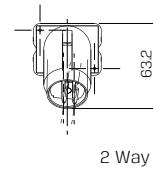
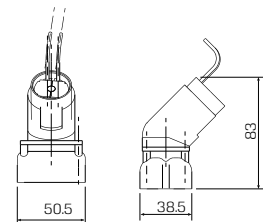

How to Order

G75-LDO - VOLTAGE - Please refer to the "How to Order" definitions of the assembled G75 valve.

24 VAC & 12-24 VDC 9

Example: G75-LDO-9-G75-A-11032B-1

G75-LDO 24V AC is attached to a G75-A with flange, 1/8" BSP, 3W NC 1.2 orifice, no manual override, 4 latch coil, two wires

G75-LDO - 9 - G75-A - 1 - 10 - 3 - 2 - B - 1

* To order special valves manufactured according to your specific requirements, please contact our technical sales department

b **BACCARA**[®]
AUTOMATION & CONTROL



OPERATORS & COILS

GEM-B Coil	104
GEM-BL Latch coil	106
GEM-BP IP68 coil	108
GEM-FLOW G75-O	AC/DC Operator 2 Way, 3 Way NC, NO.....	110
GEM-FLOW G75-O	Latch Operator 2 Way, 3 Way NC, NO.....	112



GEM-B | Coil



Technical Data

Coil winding insulation	H 180°C
Temperature range	Coil: -20°C to 150°C Ambient: -20°C to 70°C
Duty cycle *	100% ED
Electrical connection	<ul style="list-style-type: none"> • AMP pins, DIN 46242, 2 poles + 1 earth • 2 flying leads, 18 AWG (0.75mm²), 330 mm length
Connector	<ul style="list-style-type: none"> • DIN 43650 • PG9 or 1/2" NPT * Max. tightening torque for the connector screw: 0.5 Nm
Assembly	In any position
Coil fixing	One nut G1/4" hexagonal 19mm
Impregnation	Optional
Coil voltage	<ul style="list-style-type: none"> • Voltage and power consumption - see table • All Baccara coil voltages are ±10% of nominal
Standard / Certification	CE
Standard protection class	IP65 with connector * Option: IP68 (please refer to GEM-BP coil)

- The coil should not be energized without being assembled on the operator
- * Please consult with our technical sales department:
 - for further information on using different power coils (not shown in the table)
 - for long term operation



Power Consumption (AC)

Type	Inrush	Holding
8W	26VA-13W	16VA-8W
5.5W	16VA-8W	12VA
2.5W	2.5W	2.5W

Power Consumption (DC)

Type
10W
5.5W
2.5W

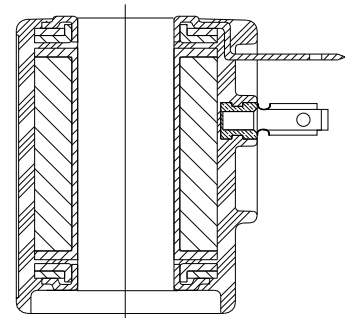

Voltage & Power Consumption

V	AC (W)						DC (W)		
	50 Hz			60 Hz			10	5.5	3.5
6							•	•	•
12	•			•			•	•	•
24	•	•		•	•	•	•		•
48	•			•			•		
110	•			•	•		•		
120	•			•					
220	•	•		•			•		
230	•	•		•	•				
240	•			•			•		

- Available options

Dimensions

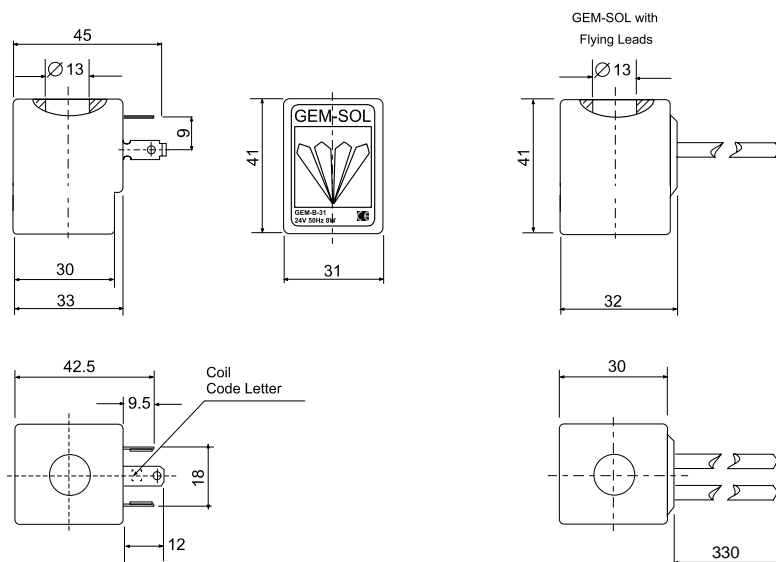

How to Order

GEM-B	-	VOLTAGE	POWER	CONNECTOR
6	1	AC8W 50Hz	1	without 0
12	2	AC8W 60Hz	2	with 1
24	3	DC10W	3	with LED 2
48	4	AC5.5W 50Hz	4	with bi- color LED 3
110	5	AC5.5W 60Hz	5	flying leads coil 4
120	6	AC2.5W 50/60Hz	6	with 1/2" hub 5
220	7A	DC5.5W	7	surge protection with LED 6
230	7	DC3.5W	8	connector with moulded cable 7
240	8			other 9
Latch/other ⁽¹⁾	9			

Example: GEM-B-341

GEM-SOL Coil 24V AC 5.5W 50Hz with connector

GEM-B - 3 4 1

(1) For specifying Latch type coil, please refer to GEM-A3P valve - How to Order table

* To order coils manufactured according to your specific requirements, please contact our technical sales department

GEM-BL | Latch coil



Technical Data

Coil winding insulation	H 180°C
Temperature range	Coil: -20°C to 150°C Ambient: -20°C to 70°C
Electrical connection	<ul style="list-style-type: none"> • AMP pins, DIN 46242, 2 poles + 1 earth • 2 flying leads, 18 AWG (0.75mm²), 330 mm length
Connector	<ul style="list-style-type: none"> • DIN 43650 • PG9 or 1/2" NPT * Max. tightening torque for the connector screw: 0.5 Nm
Assembly	In any position
Coil fixing	One nut G1/4" hexagonal 19mm
Typical pulse time	30-50ms
Impregnation	Optional
Standard / Certification	CE
Standard protection class	IP65 with connector * Option: IP68 (please refer to GEM-BP coil)

- The coil should not be energized without being assembled on the operator
- The coil, including its magnetic circuit and permanent magnets, is encapsulated in high temperature resistant nylon to withstand humidity and meet heavy duty requirements.

When ordering for a new application, please inform us of your requirements according to the table below. This will enable us to determine the most suitable coil.

VOLTAGE	OPERATING METHOD	MAX CURRENT [A] ON COIL	CAPACITOR [μF]	SWITCHING TIME [ms]
3	Direct	≤2	None	≤25
6	Capacitor	≤1	2200	≤50
9		≤0.5	4700	≤100
12		≤0.1	other	other
24		other		
230				
Other				

Example: 12V DC, Capacitor, ≤1, 4700, ≤50ms

12V	Capacitor	≤1	4700	≤50ms
-----	-----------	----	------	-------

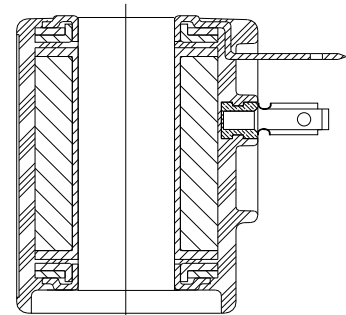

Dimensions

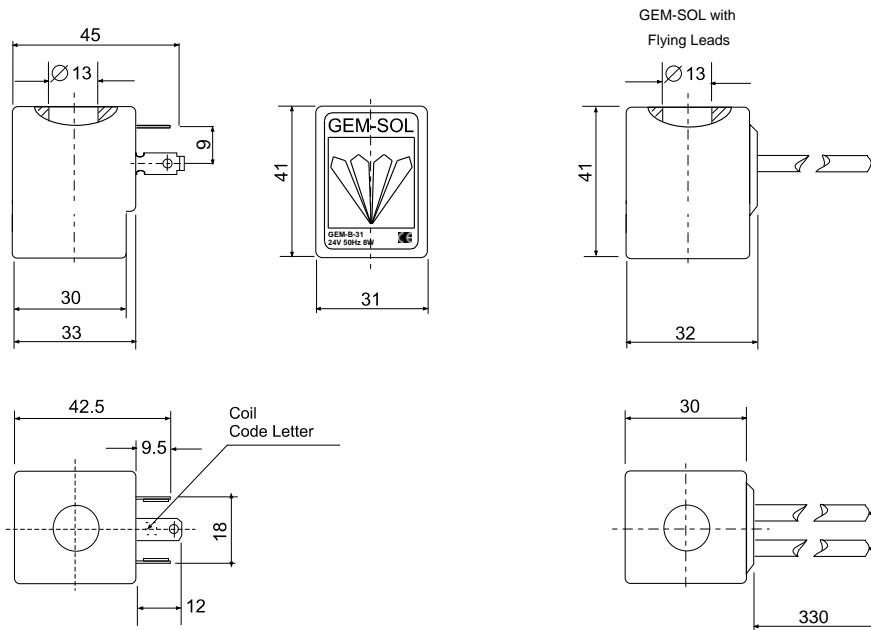

How to Order

GEM-BL	-	LATCH TYPE ⁽¹⁾	CONNECTOR	
2Ω		LDO	without	0
5Ω		IL	with	1
13Ω		EL	flying leads coil	4
20Ω		OL	with 1/2" Hub	5
53Ω		DL	connector with moulded cable	7
			other	9

Example: GEM-BL-LD01

GEM-SOL latch coil, 2 latch with connector

GEM-BL - LDO 1

(1) Choose latch type according to which latch system you have

* To order coils manufactured according to your specific requirements, please contact our technical sales department

GEM-BP | IP68 coil

Technical Data

Construction	Housing: encapsulated polyurethane
Coil winding insulation	H 180°C
Temperature range	Ambient: -5°C to 50°C (no icing)
Duty cycle	100% ED
Protection	IP68 infinite time immersion under water, up to 2m depth
Electrical connection	3x18 AWG (0.75mm ²), hook up wire, 200cm * other lengths are available
Assembly	In any position
Coil fixing	One nut G1/4" hexagonal 19mm
Standard / Certification	European Standards IEC 60529 code IP68
Coil voltage	<ul style="list-style-type: none"> • Voltage and power consumption - see table • All Baccara coil voltages are ±10% of nominal

- The coil should not be energized without being assembled on the operator

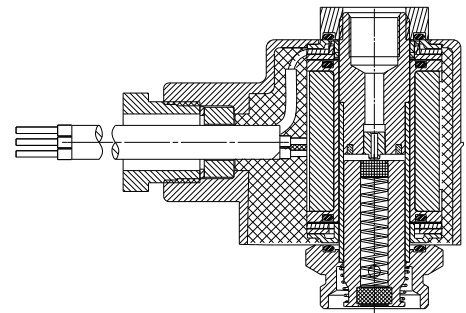

Power Consumption (AC)

Type	Inrush	Holding
8W	26VA-13W	16VA-8W
5.5W	16VA-8W	12VA
2.5W	2.5W	2.5W

Power Consumption (DC)

Type
10W
5.5W
3.5W

Voltage & Power Consumption

V	AC (W)						DC (W)		
	50 Hz			60 Hz			10	5.5	3.5
6									
12	•			•			•	•	•
24	•	•	•	•	•	•	•	•	•
48									
110									
120									
220									
230									
240									

- Available options

Dimensions

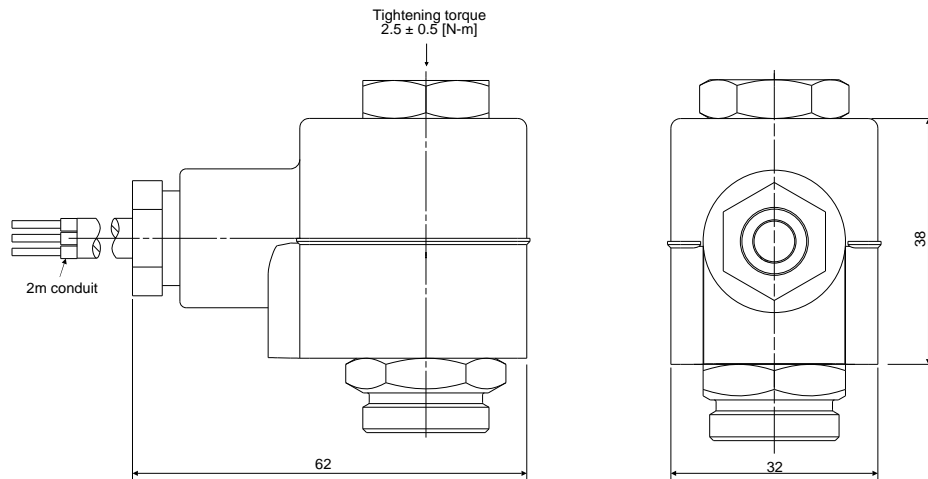

How to Order

GEM-BP	VOLTAGE	POWER
12	2	AC8W 50Hz 1
24	3	AC8W 60Hz 2
		DC10W 3
		AC5.5W 50Hz 4
		AC5.5W 60Hz 5
		AC2.5W 50/60Hz 6
		DC5.5W 7
		DC3.5W 8

Example: GEM-BP-31
IP68 GEM-SOL coil 24V AC 8W 50Hz.

GEM-BP - 3 1

* To order coils manufactured according to your specific requirements, please contact our technical sales department

GEM-FLOW | G75-0

AC/DC Operator 2 Way, 3 Way NC, NO

Applicable for G75-A, Galit, G75-S & G75-Z valves

Technical Data

Function	2 Way, 3 Way NC, NO
Orifice size	2 Way: No orifice 3 Way: See table
Pressure range (bars)	See solenoid valve performances
Temperature range	Fluid: 5°C to 50°C (no freezing) Ambient: -10°C to 50°C
Materials in contact with media	Housing: Plastic (Reinforced Nylon 66) Plunger & pole: Stainless Steel AISI 430F Rubber Seals: EPDM Encapsulate: Polyurethane Spring: Stainless Steel AISI 300 series
Media	Air, water, oil *
Threads on operator tube	G1/8" or 1/8" NPT female to connect exhaust, muffler etc
Operator assembly	By manually screwing 3/4" UNEF to valve body. • Max. tightening torque: 2 N/m
Electrical connection	Lead wires 35 cm, 18 AWG (0.75mm ²) * other lengths are available
Coil voltage	• Voltage and power consumption - see table
Standard protection class	IP66

* For other fluids and for use in abnormal conditions, please contact our technical sales department



2 Way Operator



3 Way Operator

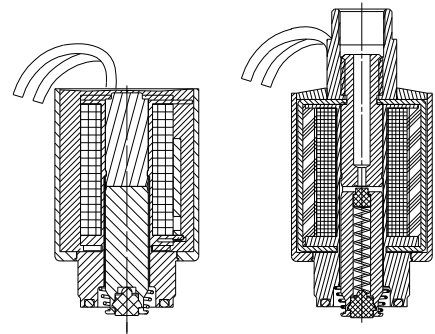

2 Way NC

3 Way NC / 3 Way NO

Working Pressure (bar) 2 Way NC

Orifice (mm)	up to 2.0
Pressure (bar)	12

Working Pressure (bar) 3 Way NC

Orifice (mm)	1.0	1.2	1.6
AC Pressure (bar)	16	11	6
DC Pressure (bar)	12	9	5

Working Pressure (bar) 3 Way NO

Orifice (mm)	1.0	1.2	1.6
Pressure (bar)	16	12	10

Voltage & Current

AC & DC

Solenoid	Voltage	Inrush [A]	Holding [A]
2 Way 50 Hz	V	+10%	0.3
2 Way 60 Hz			0.2
3 Way 50/60 Hz *			0.125
DC	n-20%		4.5W

* Except 24V AC without Diode

Voltage & Power Consumption

V	AC (W)	DC (W)
12	•	•
24	•	•
110	•	
	≥ 2 Way only	

• Available options

Dimensions

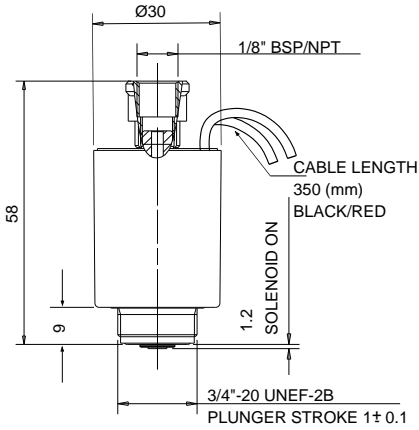

3 Way NC / 3 Way NO

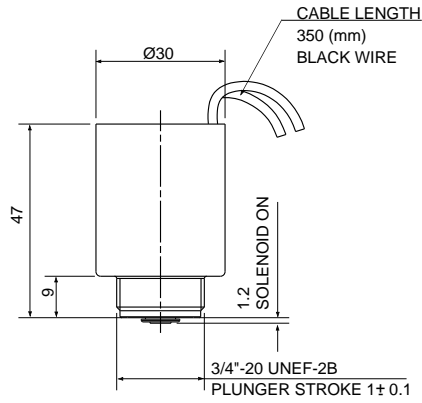

2 Way NC

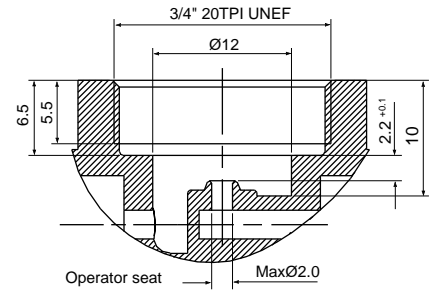

How to Order

2 Way

G75-0	-	FUNCTION	VOLTAGE	
		2W NC	1	
			24V AC	1
			24V AC w/out Diode ⁽¹⁾	1R
			12V AC	3
			12V DC	4
			24V DC	5
			110V AC	7

3 Way

G75-0	-	PORT	FUNCTION	ORIFICE	
		1/8" BSP	10	3W NC	3
		1/8" NPT	11	3W NO	4
				1.0	1
				1.2	2
				1.6	3

Example: G75-0-1-1

G75 operator, 2W NC, 24V AC

G75-0 - 1 - 1

Example: G75-0-1032-1

G75 operator, 1/8" BSP, 3W NC, DC, 1.2 orifice, NBR, 24V AC

G75-0 - 10 - 3 - 2 - 1

(1) 3W NO 1.6 mm: Max pressure is 8 bar

* To order operators manufactured according to your specific requirements, please contact our technical sales department

GEM-FLOW | G75-0

Latch Operator 2 Way, 3 Way NC, NO

Applicable for G75-A, Galit, G75-S & G75-Z valves

Technical Data

Function	2 Way, 3 Way NC, NO Latch
Orifice size	2 Way: No orifice 3 Way: See table
Pressure range (bars)	See solenoid valve performances
Capacitors	<ul style="list-style-type: none"> • 4700µF for 9V DC • 2200µF for 12V DC
Switching time	25-50 ms
Temperature range	Fluid: 5°C to 50°C (no freezing) Ambient: -10°C to 50°C
Materials in contact with media	Housing: Plastic (Reinforced Nylon 66) Plunger & pole: Stainless Steel AISI 430F Rubber Seals: EPDM Encapsulate: Polyurethane Spring: Stainless Steel AISI 300 series
Threads on operator tube	G1/8" or 1/8" NPT female to connect exhaust, muffler etc
Two wire operator	One coil with exit of 2 lead wires. To pull the plunger up, connect the black wire (-) and the green to the (+).
Three wire operator	One coil and an integrated electrical circuit. To pull plunger up, pulse is given to the red wire (-). To release the plunger, pulse is given to the black wire (-). Operate only by a controller.
Electrical connection	<ul style="list-style-type: none"> • Lead wires 35 cm, 18 AWG (0.75mm²) (black/green) • Lead wires: red, white, black for 3 wires
Voltage	9, 12V DC (coils for other voltages available)
Standard protection class	IP66



2 Way Operator



3 Way Operator

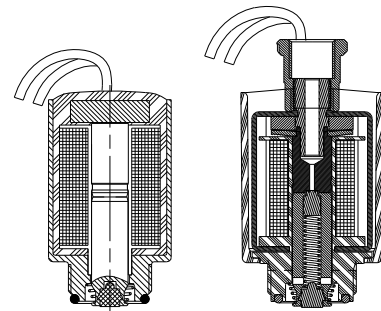

2 Way NC

3 Way NC / 3 Way NO

Working Pressure (bar) 2 Way NC

Orifice (mm)	up to 2.0
Pressure (bar)	12

Working Pressure (bar) 3 Way NC

Orifice (mm)	1.0	1.2	1.6
AC Pressure (bar)	16	11	6

Working Pressure (bar) 3 Way NO

Orifice (mm)	1.0	1.2	1.6
Pressure (bar)	16	12	10

Dimensions

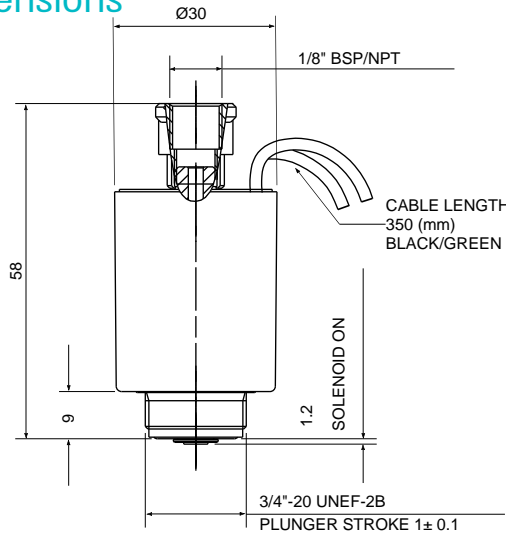

3 Way NC / 3 Way NO

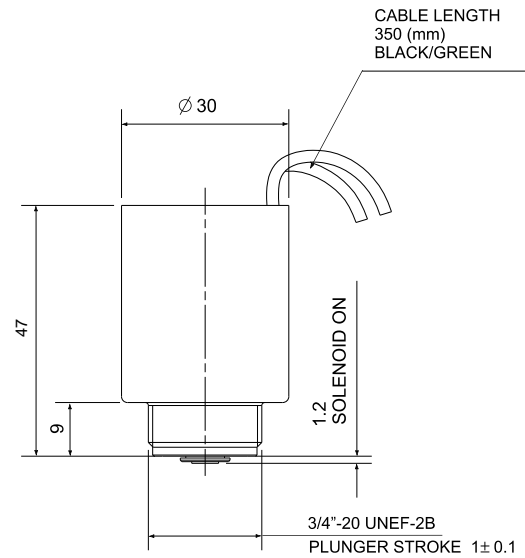

2 Way NC

How to Order

2 Way

G75-0	FUNCTION	VOLTAGE VDC ⁽¹⁾	WIRES
	2W NC 1	4Ω B	two null

3 Way

G75-0	PORT	FUNCTION	ORIFICE	VOLTAGE VDC ⁽¹⁾	WIRES
	1/8" BSP 10	3W NC 3	1.0 1	9Ω C	three a
	1/8" NPT 11	3W NO 4	1.2 2	12Ω D	
			1.6 3	23Ω 6	

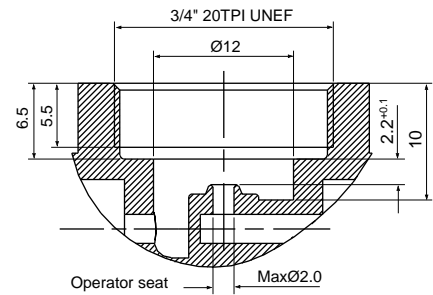

Latch Coil Resistance vs Input Voltage

Recommendations chart

Resistance [Ω]	Input voltage range [V]
4	6 - 9
9	12 - 14
12	14 - 16
23	18 - 21

Example: G75-0-1-Ba

G75 latch solenoid operator, 2W NC, 4 Ω, 3 wires

G75-0 - 1 - B - a

Example: G75-0-1042-Ca

G75 latch solenoid operator, 1/8" BSP, 3W NO, 1.2 orifice, 9 Ω, 3 wires

G75-0 - 10 - 4 - 2 - C - a

(1) Refer to Latch Coil Resistance vs Input Voltage | Recommendations chart

* To order operators manufactured according to your specific requirements, please contact our technical sales department



TECHNICAL INFORMATION

Valve Functions	116
Operating Mechanism	117
Valve Sizing	118
GEM-SOL Elastomer Materials	119
Flow Chart for Liquids	120
Flow Chart For Gases	121
Operation Driver for Latch Coils	122
Conduits Sizing	123
Long Distance Operators Charts	124



Valve Functions

Two way valves have one orifice and two ports: one inlet and one outlet. They are available with the following functions:

- Normally Closed (NC) Fig. 1 - valve is closed for flow through the valve when the coil is de-energized.
- Normally Open (NO) Fig. 2 - valve is open for flow through the valve when the coil is de-energized.

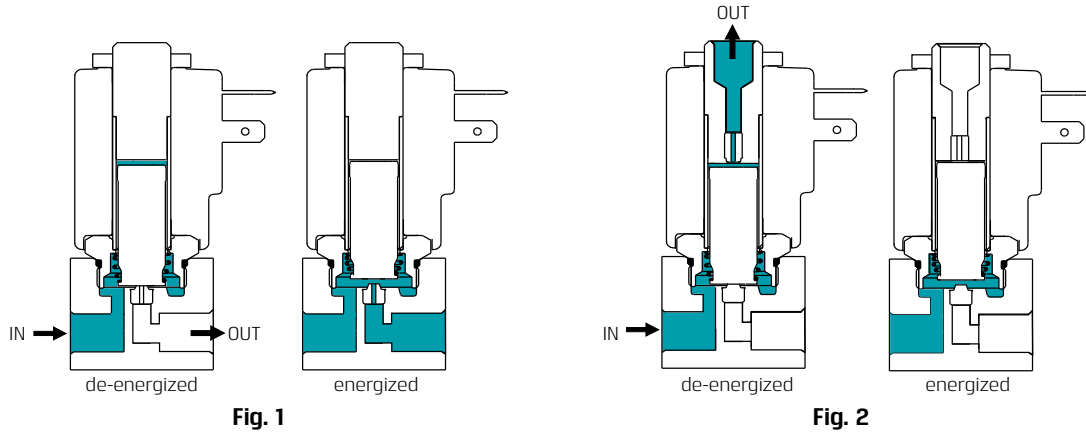

Three way valves have two orifice and three ports: inlet, outlet and exhaust. They are available with the following functions:

- Normally Closed (NC) Fig. 3 - no flow from inlet port, flow is from outlet port to the exhaust.
- Normally Open (NO) Fig. 4 - flow from inlet port, no flow from the exhaust port.

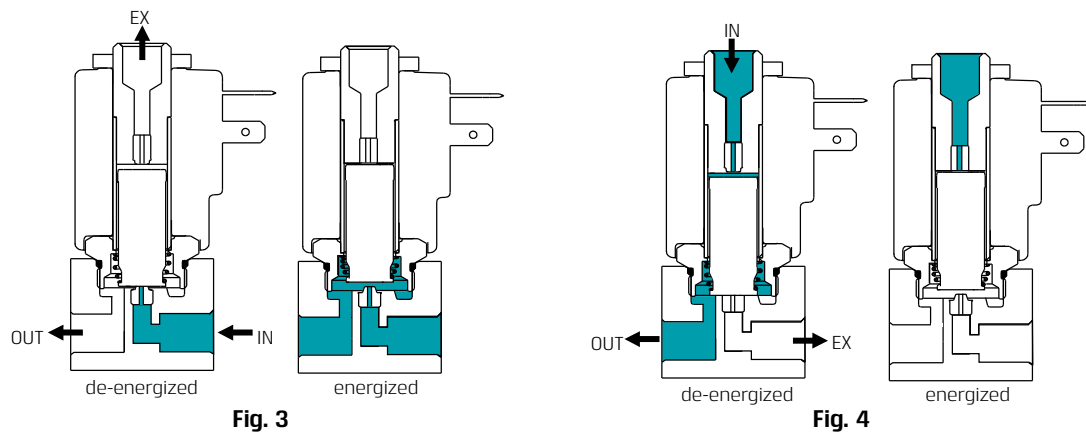

Also available are the following non-standard functions: Divertor Fig. 5 - one inlet pressure with two outlets, one outlet is NO and the other NC. Selector Fig. 6 - two inlet pressures, one inlet is NO and the other NC.

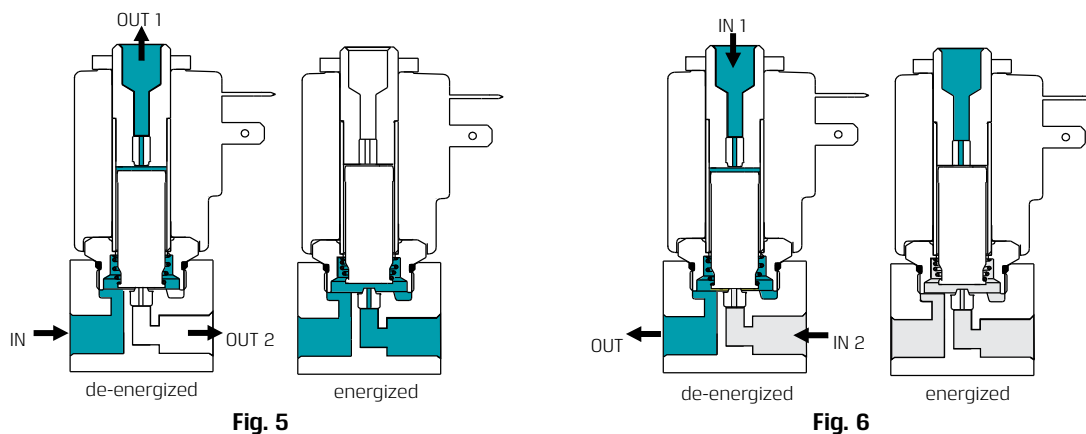

Operating Mechanism

A solenoid valve is a combination of two functional units:

- A solenoid (electromagnet) with a moving core (plunger).
- A valve body containing the right orifices and seals mechanism.

The plunger in a solenoid valve moves and changes the flow direction when a current is supplied to the electromagnet.

There are two basic types of Baccara GEM-SOL valves:

Direct operated solenoid valves

When the solenoid is energized in a direct acting valve, the plunger moves and directly acts on the valve disc to open, close or change the flow direction. Direct acting valves' performance depends directly on the orifice pressure and the magnetic power. The increase of line pressure or the orifice size requires more power from the electromagnet.

Pilot operated solenoid valves

These valves are recommended for applications where high flow at high pressure is required. A pilot chamber is used which is controlled by a direct acting solenoid valve. The movement of the plunger changes the pressure in the pilot chamber.

When there is pressure in the pilot chamber the valve is closed. GEM-SOL pilot valves are equipped with diaphragm, according to the valve function.

- Two way valves have a bleeding passage in the diaphragm, through which the pilot pressure flows into the pilot chamber; and one orifice to release the pressure when the solenoid is energized.
- Three way valves have a three way pilot solenoid to control the pilot chamber pressure.
- Pilot operated valves require a minimum operating pressure.

Zero differential valves

We also manufacture a two way pilot operated valve which works without differential pressure. For this type of valve, a mechanical spring helps to lift the diaphragm.

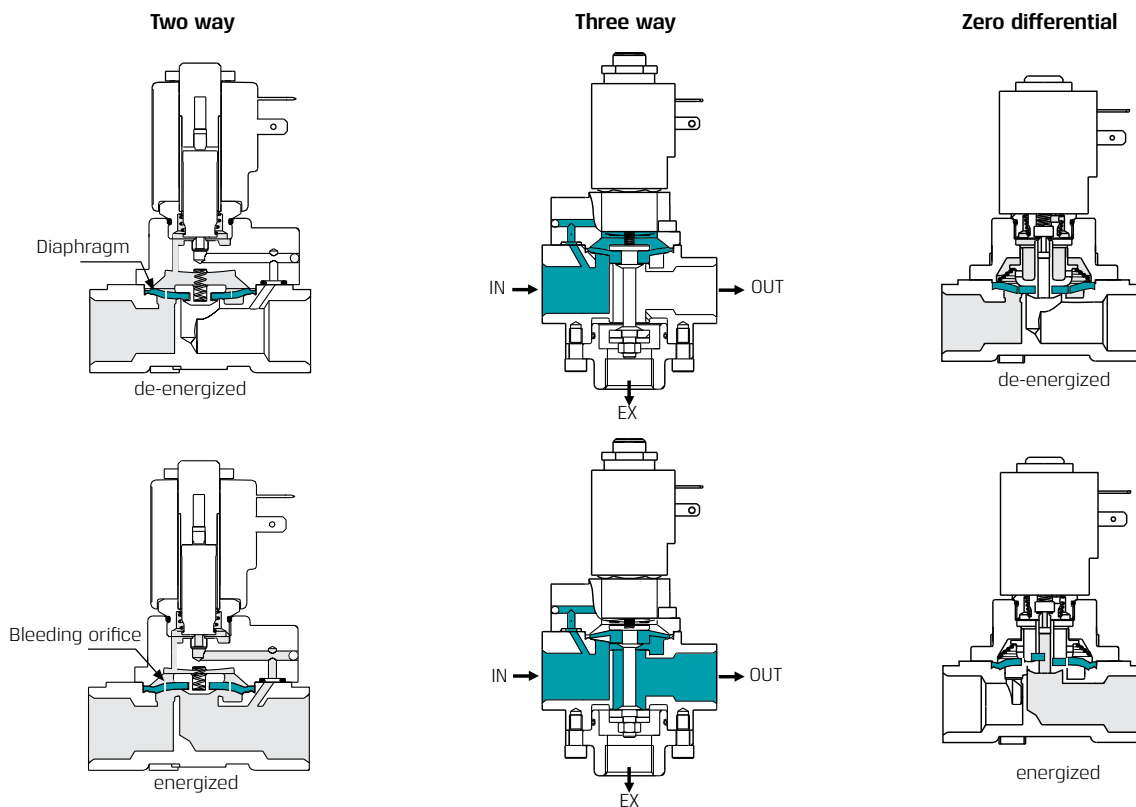

Valve Sizing

General

It is not recommended to select a solenoid valve according to its pipe connection port or its orifice size. The valve selection depends on the knowledge of the following factors: pressure range minimum and maximum, differential pressure, minimum and maximum flow rate, the specific gravity of the fluid, temperature, viscosity, etc.

Pressure

The pressure is generally measured above the atmospheric pressure and is expressed in kg/cm² or bars of relative pressure.

The value of pressure terms in this catalog corresponds to the relative pressure.

Pressure drop ΔP

This is the difference of pressure between the upstream P1 and the downstream P2 of the valve when it is crossed by the fluid.

Differential pressure

Minimum - maximum

This is the minimum or maximum difference of pressure between the upstream P1 and the downstream P2 which secures perfect functioning of the device. Only a pilot operated solenoid valve requires the minimum differential pressure to operate.

Flow - the flow factor Kv (Cv)

The flow of a solenoid valve is the quantity of fluid per time units crossing the valve under certain conditions. It is this factor which determines its size. To obtain a simpler method of calculation and comparison between the various types of valves, all variables permitting the calculation of the flow have been reduced to a common denominator: the flow factor Kv (without units). The Kv factor can be determined by the flow chart or by calculation. When the Kv factor is determined, select the solenoid valve which has the equivalent flow factor. The flow factor values given in this catalog have been set up according to the following method:

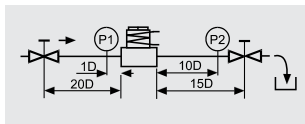

Fluid is water, specific gravity 1 kg/dm³ the pressure drop P1, P2 is 1Kg/cm² in a way that the Kv is equal to the flow in liter/min.

$$Q = Kv \sqrt{\frac{\Delta P}{\gamma}} \quad Kv = Q \sqrt{\frac{\gamma}{\Delta P}}$$

When several valves are mounted in series, the resulting flow factor is equal to:

$$\frac{1}{Kv_{Tot}^2} = \frac{1}{Kv_1^2} + \frac{1}{Kv_2^2} + \frac{1}{Kv_3^2} + \dots + \frac{1}{Kv_n^2}$$

When several valves are mounted in parallel, the resulting flow factor is equal to:

$$Kv_{Tot} = Kv_1 + Kv_2 + Kv_3 + \dots + Kv_n$$

Unit conversion
Kv = flow factor (decimal units)
to convert
CV(USA) = 0.070Kv
f(UK) = 0.0585Kv
Kv = 14.28 Cv (USA)
Kv = 17.11 f (UK)

Viscosity

Practically, the flow Kv is identical for a valve crossed by water or a medium having up to 3°E viscosity. The flow/pressure characteristic is effected above this limit. It is necessary to consider factor above 3°E - the flow factor Kv will be:

$$Kv_x = Kv_{water} \cdot C$$

$$C = \frac{\delta \sqrt{Kv}}{200 Q} + 1$$

δ = kinematic viscosity (in centistokes) of the fluid

Q = flow in liter/min

Kv = flow factor given in catalog

This calculation leads to a choice of a valve with a higher flow factor value than the one which would have been chosen for a fluid having a viscosity of 3°E.

Temperature

The limits of temperature of use of a solenoid valve depend essentially upon the nature of the discs and the design of the coil. The temperature developed in a solenoid valve is a function of the electrical characteristics of the coil, the duty cycle, the fluid and ambient temperatures. These parameters determine the "temperature of use".

For each type of solenoid valve, the temperature range is given in the technical data, however these figures are only a general guide. If temperature of use might extend the given limits, please contact our technical sales department.

Response time

The response time of a solenoid valve is the lapse of time between the electric signal and the outlet of fluid signal. The response time is effected by the following parameters:

Valve function, operating mode, orifice size, inlet pressure and pressure differential, fluid, temperature and coil characteristics. The C.E.T.O.P defines the test of conditions as follows:

Test pressure: air at 6Kg/cm² - 85 PSI

Ambient temperature: 200 C - 680 F

Response time at energizing

Response time at energizing of the solenoid and until the outlet pressure reaches 90% of the test pressure.

Response time at de-energizing

Lapse of time between de-energizing of the solenoid and until the pressure outlet drops to 10% of the test pressure, see schemas of measure method and resulting curves for AC and DC current.

Average response time for GEM-SOL valves can be assumed as follows:

- Direct acting solenoids 16 to 36 ms for complete cycle.
- Large direct acting solenoids 40 to 80 ms for complete cycle.
- Pilot operated valve 20 to 80 ms for complete cycle.

Cycling rate

The cycling rate of a solenoid depends directly on its response time. It is the number of cycles per minutes calculated for continuous operation. The valve should not be reversed at less than 90% or above 10% at discharging of reference pressure.

$$\text{Cycles/Minutes} = \frac{60 \text{ sec}}{R_e + R_d}$$

R_e = response time at energizing (sec)
R_d = response time at de-energizing (sec)

The cycling rate is the maximum possible cycles per minute of the solenoid valve. It varies when the valve is mounted in a circuit and depends then upon the installation pressure drop.

GEM-SOL Elastomer Materials

General information

GEM-SOL solenoid valves can be used for many fluid types including acids, gases, solvents etc. To ensure appropriate functioning of the valve, particular care must be taken with the selection of the valve and seals materials. The information below summarizes the elastomers materials used for GEM-SOL valves.

Please contact our technical department for further information.

NBR or BUNA-N

- NBR is a copolymer of butadiene and acrylonitrile. It is the most used elastomer in the seals industry and is the standard elastomer for GEM-SOL valves.
- NBR is suitable for use from -20°C to 85°C. It has benefits over other elastomers with its compression set, tear and abrasion resistance.
- Air, cold water and inert gases are some of the materials NBR is recommended for.

EPDM - Ethylene Propylene Rubber

- EPDM is an elastomer made from ethylene and propylene monomers. It has a wider temperature range than NBR, -40°C to 149°C. Its main disadvantage is that it cannot be used with petroleum oils.
- Water, alcohol and acetone are some of the materials EPDM is recommended for.

Neoprene

- Neoprene is homopolymers of chloroprene. It has a temperature range of -20°C to 85°C. Neoprene is unusual because it is resistant to both oxygen and petroleum.
- Refrigerants, oxygen and petroleum oils are some of the materials Neoprene is recommended for.

FKM

- FKM is a very important elastomer due to its wide compatibility to chemicals. It has a temperature range of -20°C to 180°C. This gives FKM a significant advantage over NBR, but it is still not the ultimate elastomer.
- Diesel oil, gasoline, some acids and trichlorethylene are some of the materials FKM is recommended for.

Flow Chart for Liquids

Kinematic viscosity: Max. 3^o Engler

Spec. gravity
 γ (Kg/dm³)

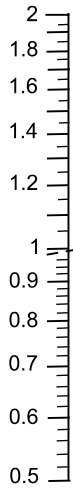

Flow factor
 Kv

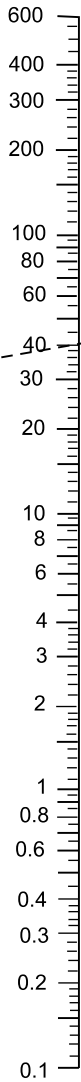

Flow rate
 Q (l/min)

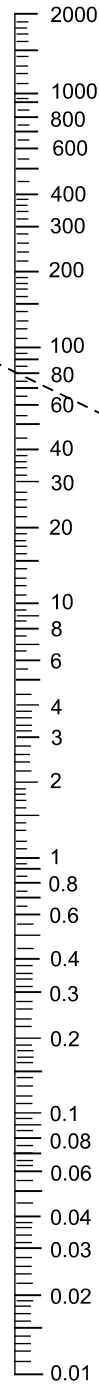

Pressure drop
 Δ_p (bar)

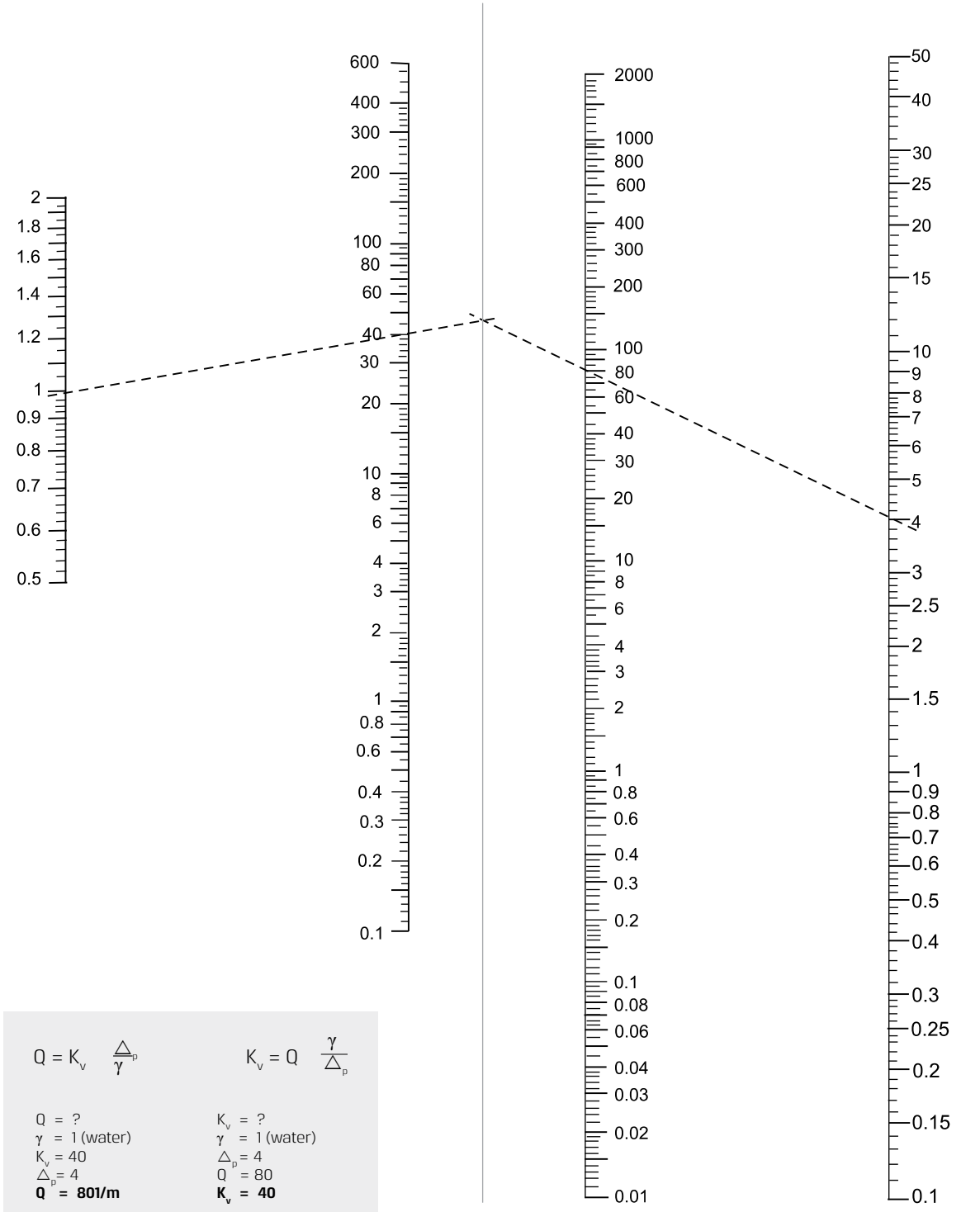
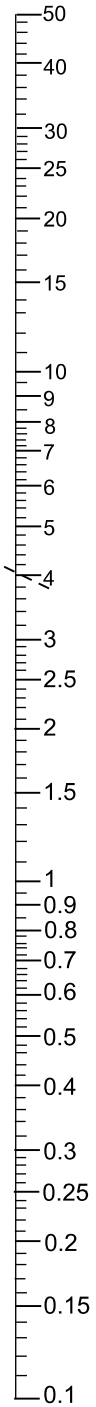

$Q = K_v \frac{\Delta_p}{\gamma}$	$K_v = Q \frac{\gamma}{\Delta_p}$
Q = ? $\gamma = 1$ (water) K _v = 40 Δ _p = 4 Q = 80 l/m	K _v = ? $\gamma = 1$ (water) Δ _p = 4 Q = 80 K_v = 40

Flow Chart For Gases

Spec. gravity
 γ_N (Kg/m³)

Flow factor
Kv

Flow rate
QN (Nm³/h)

Pressure drop
 Δ_p (bar)

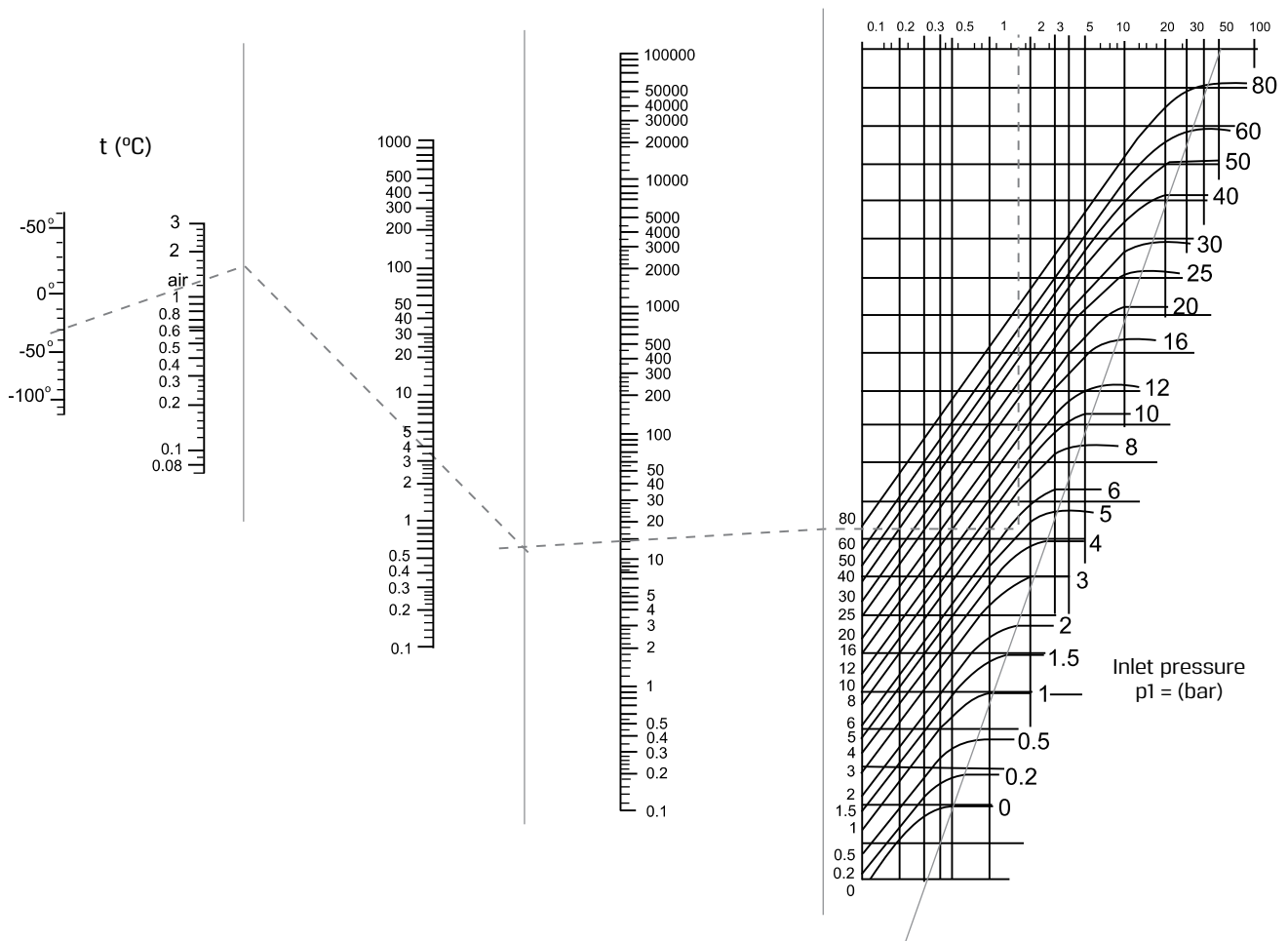

QN = ?	Kv = ?
t = 25	t = 25
γ_N = 1.3 (air)	γ_N = 1.3 (air)
Kv = 3	QN = 12
p1 = 5	p1 = 5
Δ_p = 1.8	Δ_p = 1.8
QN = 12 Nm³/h	Kv = 3

Operation Driver for Latch Coils

Non-direct operation with two switches (or four transistors)

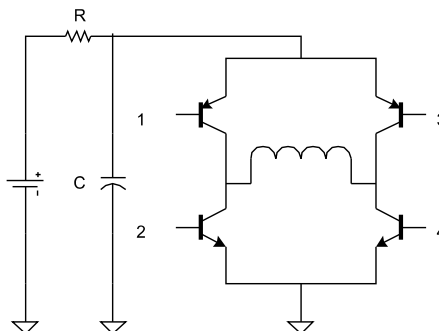
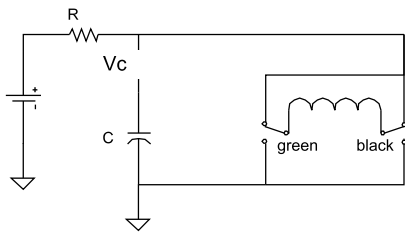

T_{vc} is the time to charge the capacitor. In order to reduce the time, use a similar resistor but never less than 100Ω.

$C = 4700\mu F$

$T_{vc} = 5 \cdot R \cdot C$ [sec]

$t_{on/off} = 30 \div 50$ ms

Non-direct operation with one switch (or transistor)

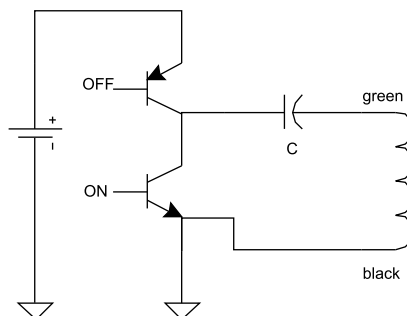
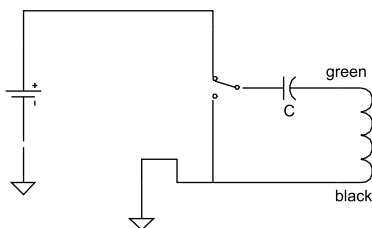

$C = 4700\mu F$

$t_{on/off} = 30 \div 50$ ms

Direct operation

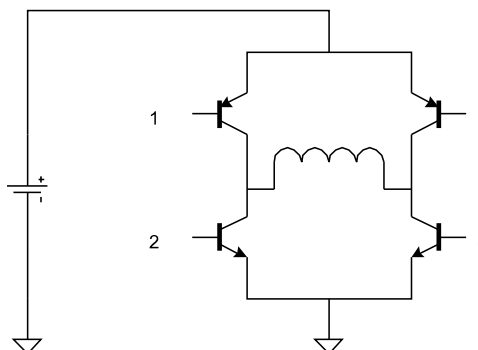
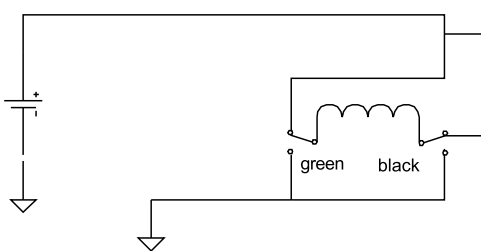

Conduits Sizing

GEM-SOL

Wires cross-section selection for distance installation of GEM-SOL solenoids

Solenoid type: GEM-SOL 8W 24V AC					
No. of solenoids	1	2	3	4	Distance
Cross-section [mm ²]	1.0	1.5	2.5	4.0	100m
	1.5	4.0	6.0	6.0	200m
	2.5	6.0			300m
	4.0	6.0			400m
	4.0				500m
	6.0				600m
	6.0				700m
	6.0				800m
					900m
				1000m	

Max. conduits resistance 4

Solenoid type: GEM-SOL 5.5W 24V AC					
No. of solenoids	1	2	3	4	Distance
Cross-section [mm ²]	0.75	1.5	2.5	2.5	100m
	1.5	2.5	4.0	6.0	200m
	2.5	4.0	6.0		300m
	2.5	6.0			400m
	4.0				500m
	4.0				600m
	6.0				700m
	6.0				800m
	6.0				900m
				1000m	

Max. conduits resistance 5

G75

Wires cross-section selection for distance installation of G75 solenoids

Solenoid type: G75 24V AC					
No. of solenoids	1	2	3	4	Distance
Cross-section [mm ²]	0.5	0.5	0.75	1.0	10m
	0.5	1.0	1.5	2.5	200m
	0.75	1.5	2.5	2.5	300m
	1.0	2.5	2.5	4.0	400m
	1.5	2.5	4.0	6.0	500m
	1.5	4.0	4.0	6.0	600m
	2.5	4.0	6.0	6.0	700m
	2.5	4.0	6.0		800m
	2.5	4.0	6.0		900m
	2.5	6.0			1000m

Max. conduits resistance 15

Solenoid type: G75 latch 4Ω					
No. of solenoids	1	2	3	4	Distance
Cross-section [mm ²]	0.75	1.5	1.5	2.5	10m
	1.5	2.5	4.0	6.0	20m
	1.5	4.0	6.0	6.0	30m
	2.5	6.0	6.0		40m
	4.0	6.0			50m
	4.0				60m
	4.0				70m
	6.0				80m
	6.0				90m
	6.0				100m

Max. conduits resistance 0.6

Long Distance Operators Charts

LDOS | Long distance operating solenoid

Number of solenoids that operate simultaneously as a function of wire cross-sectional [mm ²] area and distance [mt] from energy source				
Distance in meters from energy source	WIRE CROSS-SECTIONAL AREA [mm ²]			
	0.50	1.00	1.50	2.50
200	12	25	38	65
400	6	12	19	40
600	4	8	12	21
800	3	6	9	16
1,000	2	5	7	13
1,500	1	3	5	9
2,000	1	2	3	6
2,500	1	2	3	5
3,000		1	2	4
3,500		1	2	4
4,000		1	2	3
5,000		1	1	2
6,000			1	2
7,000			1	1
8,000			1	1
9,000				1
10,000				1

Wire's maximum resistance for one solenoid is 175

For further technical information, please refer to product pages in Controllers & Special section



LDOS | assembled with GEM-S solenoid

G75-LDO | Long distance operator 2 Way, 3 Way NC, NO

GEM-LDO | Long distance operator 2 Way, 3 Way NC, NO

Number of solenoids that operate simultaneously as a function of wire cross-sectional [mm ²] area and distance [mt] from energy source				
Distance in meters from energy source	WIRE CROSS-SECTIONAL AREA [mm ²]			
	0.50	1.00	1.50	2.50
200	24	56	78	130
400	12	28	39	65
600	8	18	26	43
800	6	14	19	32
1,000	4	11	15	26
1,500	3	7	10	17
2,000	2	5	7	13
2,500	2	4	6	10
3,000	1	3	5	8
3,500	1	3	4	7
4,000	1	2	3	6
5,000	1	2	3	5
6,000		1	2	4
7,000		1	2	3
8,000		1	1	3
9,000		1	1	2
10,000		1	1	2

Wire's maximum resistance for one solenoid is 390

For further technical information, please refer to product page in Controllers & Special section



G75-LDO | assembled with G75-A operator & solenoid

GEM-LDO | assembled with GEM-A solenoid

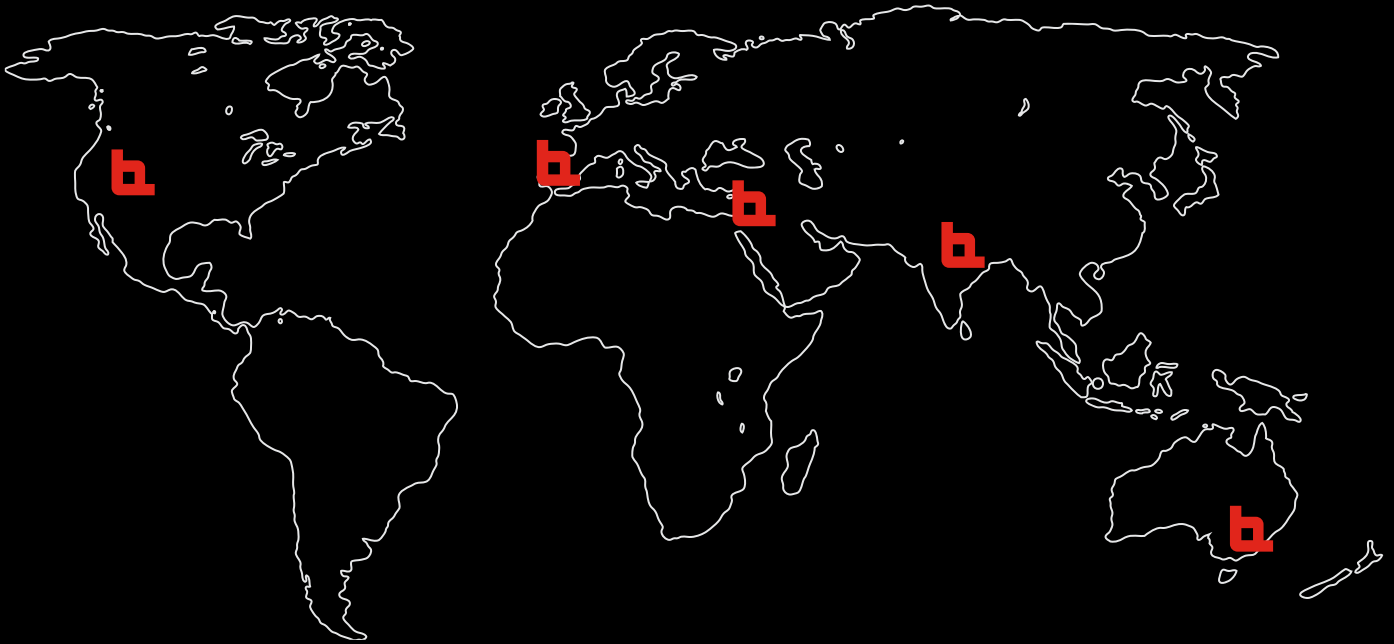

BACCARA WORLD WIDE

BACCARA Corporate Headquarters

Kvutzat Geva, 1891500, Israel

T. +972 4 6535960

F. +972 4 6535950

info@baccara-geva.com

www.baccara-geva.com

Baccara Australia Pty Ltd.

15/347 Bay Rd. Cheltenham | VIC,

Australia 3192

T. +61 (0) 3 9553 4963

F. +61 (0) 3 9553 4965

Cheltenham, Victoria 3192 Australia

australia@baccara-geva.com

www.baccarageva.com.au

Store: www.baccarastore.com.au

BACCARA España

C/ Marqués de Monteagudo N° 24, Madrid

T. (+34) 913446310

spain@baccara-geva.com

<https://www.linkedin.com/company/baccara-espana/>

Baccara USA

1312 W Stanford Ave

Englewood, CO 80110

T. 719-304-4224

F. 520 746 9390

info.us@baccara-geva.com

www.baccarausa.com

Baccara India

Empirical Business Center,

Office no. 405, Navale Icon, Near

Navale Bridge, Off NH4, Narhe,

Pune. PIN- 411041. [Maharashtra]

T. +91 90 499 94197

vishal@baccara-geva.com

